

15 DECEMBER 1998

**M977 SERIES, 8 X 8 HEAVY EXPANDED  
MOBILITY TACTICAL TRUCKS (HEMTT)**

**TRUCK, CARGO, WITH WINCH M977  
(NSN 2320-01-097-0260)**

**TRUCK, CARGO, WITHOUT WINCH M977  
(NSN 2320-01-099-6426)**

**TRUCK, TANK, FUEL WITH WINCH M978  
(NSN 2320-01-097-0249)**

**TRUCK, TANK, FUEL WITHOUT WINCH M978  
(NSN 2320-01-1 00-7672)**

**TRUCK, TRACTOR, WITH WINCH, WITHOUT  
CRANE M983 (NSN 2320-01-097-0247)**

**\*TRUCK WRECKER-RECOVERY M984  
(NSN 320-01-097-0248)**

**TRUCK, WRECKER-RECOVERY M984A1  
(NSN 2320-01-1 95-7641)**

**TRUCK, CARGO, WITH WINCH M985  
(NSN 2320-01-097-0261)**

**\* \* TRUCK CARGO, WITH WINCH M985E1  
(NSN 2320-01-194-7032)**

**\* \* TRUCK CARGO WITHOUT WINCH M985E1  
(NSN 2320-01-194-7031)**

This lubrication order supersedes LO 9-2320-279-12 dated 8 December 1987.

**Distribution Statement A.**

**Approved for public release; distribution is unlimited.**

\* Chassis lubrication instructions only. Refer to LO 9-2320-354-20 for lubrication instructions for HIAB Model 8109 crane.

\*\* Chassis lubrication instructions only. Refer to LO 9-2320-355-20 for lubrication instructions for HIAB Model 8108 crane.

Reference: TM 9-2320-279-10, TM 9-2320-279-20-1, TM 9-2320-279-20-2, TM 9-2320-279-20-3, TM 9-2320-355-10, TM 9-2320-354-10, TM 9-2320-355-24&P, TM 9-2320-354-24&P, LO 9-2320-355-20, LO 9-2320-354-20, and TB 750-651.

M983 with crane and M985E1 without winch are no longer in the fleet. Ignore all references to these vehicles. The M984E1 and M984A1 are the same vehicle. All references to M984E1 shall be interpreted as the M984A1 model.

*Intervals (on-condition or hardtime) and the related man-hour times are based on normal operation.* The man-hour time specified is the time needed to do all the services prescribed for a particular interval. On-condition (OC) oil sample intervals shall be applied unless changed by the Army Oil Analysis Program (AOAP) laboratory. Change the hardtime interval if lubricants are contaminated or if operating the equipment under adverse operating conditions, including longer-than-usual operating hours. The calendar interval may be extended during periods of low activity. If extended, adequate preservation precautions must be taken. Hardtime intervals will be applied in the event AOAP laboratory support is not available. Hardtime intervals must be applied during the warranty period.

Intervals shown in this lubrication order are based on calendar and hourly times or calendar times and mileage. An example of a calendar and hourly lubrication interval is: **M/60 HR**, in which **M** stands for monthly and **60 HR** stands for 60 hours of vehicle operation. An example of a mileage and calendar interval is: **1.5/Q**, in which **1.5** stands for **1,500** miles (2400 km), and **Q** stands for quarterly (every three months). The lubrication is to be performed at whichever interval occurs first for the vehicle. Special lubrication intervals and services are shown by the use of asterisk (\*) symbols.

*Determination of operating hours.* The reading on the vehicle hourmeter, which is part of the tachometer in the driver's instrument panel, is the basis of all lubrication intervals that are based on hours of operation. When hour-based intervals are shown for components that are operated for only part of the vehicle operating time, use the hourmeter reading to determine the interval, because the proportions of component vs vehicle operating time have already been figured into the intervals shown in the lubrication order.

Example: Lift Cylinder Pivot of M977 and M985 crane shows lubrication interval of Q/250 HR. This means that the lift cylinder pivot is to be lubricated every three months or every 250 hours of *vehicle* operation, whichever comes first.

### **WARNING**

Adhesives, solvents, and sealing compounds can burn easily, can give off harmful vapors, and are harmful to skin and clothing. To avoid injury or death, keep away from open fire and use in well-ventilated area. If adhesive, solvent, or sealing compound gets on skin or clothing, wash immediately with soap and water.

*Cleaning fittings before lubrication.* Clean parts with dry cleaning solvent (SD P-D-680) or equivalent. Dry before lubricating. Dotted arrow points indicate lubrication on both sides of the equipment.

*Lubrication after fording.* If fordings occur, lubricate all fittings below fording depth and check submerged gearboxes for presence of water.

*Lubrication after high-pressure washing.* After a thorough washing, lubricate all grease fittings and oilcan points outside and underneath vehicle.

*Level of maintenance.* The lowest level of maintenance authorized to lubricate a point is indicated by either Operator/crew (C) or Organizational Maintenance (O). Operator/crew (C) may lubricate points authorized for Organizational Maintenance (O) when authorized by Organizational Maintenance (O). Notes are located on cards 32 through 35.

*Localized views.* A reference to the appropriate localized view is given after most lubrication entries. Localized views begin on card 18.

*Reporting errors and recommending improvements.* You can help improve this manual. If you find any mistakes or if you know of a way to improve the procedure, please let us know. Mail your letter or DA Form 2028 (Recommended Changes to Publications and Blank forms) direct to: Commander, U.S. Army Tank-automotive and Armaments Command, ATTN: AMSTA-AC-NML, Rock Island, IL 61299-7630. A reply will be furnished direct to you.

INSERT LATEST UPDATED PAGES/WORK PACKAGES, DESTROY SUPERSEDED DATE

## LIST OF EFFECTIVE PAGES/WORK PACKAGES

NOTE: The portion of text affected by the updates is indicated by a vertical line in the outer margins of the page. Updates to illustrations are indicated by miniature pointing hands. Updates to wiring diagrams are indicated by shaded areas.

Dates of issue for original and updated pages/work packages are:

Original ... 0 ..... December 1998                      Change ... 2 ..... 15 March 2003  
 Change ... 1 ..... 15 February 2002

**TOTAL NUMBER OF PAGES IN THIS PUBLICATION IS 35  
 CONSISTING OF THE FOLLOWING:**

Page/WP No.	*Change No.	Page/WP No.	*Change No.	Page/WP No.	*Change No.
Card 1	1	Card 4 - Card 5	0	Card 32 - Card 33	1
Card 2	0	Card 6	1	Card 34 - Card 35	0
Card 3	2	Card 7 - Card 31	0	Blank	1

\* Zero in this column indicates an original page.



CHANGE

NO. 2

HEADQUARTERS  
DEPARTMENT OF THE ARMY  
WASHINGTON, D.C., 15 March, 2003

## LUBRICATION ORDER

M977 SERIES, 8 X 8 HEAVY EXPANDED MOBILITY  
TACTICAL TRUCKS (HEMTT)

MODEL	NSN
TRUCK, CARGO, WITH WINCH, M977	2320-01-097-0260
TRUCK, CARGO, WITHOUT WINCH, M977	2320-01-099-6426
TRUCK, TANK, FUEL, WITH WINCH, M978	2320-01-097-0249
TRUCK, TANK, FUEL, WITHOUT WINCH, M978	2320-01-100-7672
TRUCK, TRACTOR, WITH WINCH, WITHOUT CRANE, M983	2320-01-097-0247
TRUCK, TRACTOR, WITH WINCH, WITH CRANE, M983	2320-01-099-6421
TRUCK, WRECKER-RECOVERY, M984	2320-01-097-0248
TRUCK, WRECKER-RECOVERY, M984A1	2320-01-195-7641
TRUCK, CARGO, WITH WINCH, M985	2320-01-097-0261
TRUCK, CARGO, WITHOUT WINCH, M985	2320-01-100-7673
TRUCK, CARGO, WITH WINCH, M985E1	2320-01-194-7032
TRUCK, CARGO, WITHOUT WINCH, M985E1	2320-01-194-7031

Approved for public release; distribution is unlimited.

**LO 9-2320-279-12, February 2002, is changed as follows:**

1. Remove old pages and insert new pages as indicated below.
2. New or changed material is indicated by a vertical bar in the margin of the page.
3. Minor changes to illustrations are indicated by a miniature pointing hand.
4. Illustrations that are new or that have major revisions are indicated by a vertical bar adjacent to the illustration.

Remove Pages

A/(B blank)

3 and 4 of 35

Insert Pages

A/(B blank)

3 and 4 of 35

Copy of this lubrication order will remain with the equipment at all times; instructions contained herein are mandatory.

By Order of the Secretary of the Army:

ERIC K. SHINSEKI  
*General, United States Army*  
*Chief of Staff*

Official:



JOEL B. HUDSON  
*Administrative Assistant to the*  
*Secretary of the Army*  
0221908

DISTRIBUTION: To be distributed in accordance with the initial distribution requirements for (IDN) 380553, requirements for LO 9-2320-279-12.

CHANGE

NO. 1

HEADQUARTERS  
DEPARTMENT OF THE ARMY  
WASHINGTON, D.C., 15 February 2002

LUBRICATION ORDER

M977 SERIES, 8 X 8 HEAVY EXPANDED MOBILITY  
TACTICAL TRUCKS (HEMTT)

MODEL	NSN
TRUCK, CARGO, WITH WINCH, M977	2320-01-097-0260
TRUCK, CARGO, WITHOUT WINCH, M977	2320-01-099-6426
TRUCK, TANK, FUEL, WITH WINCH, M978	2320-01-097-0249
TRUCK, TANK, FUEL, WITHOUT WINCH, M978	2320-01-100-7672
TRUCK, TRACTOR, WITH WINCH, WITHOUT CRANE, M983	2320-01-097-0247
TRUCK, TRACTOR, WITH WINCH, WITH CRANE, M983	2320-01-099-6421
TRUCK, WRECKER-RECOVERY, M984	2320-01-097-0248
TRUCK, WRECKER-RECOVERY, M984E1	2320-01-195-7641
TRUCK, CARGO, WITH WINCH, M985	2320-01-097-0261
TRUCK, CARGO, WITHOUT WINCH, M985	2320-01-100-7673
TRUCK, CARGO, WITH WINCH, M985E1	2320-01-194-7032
TRUCK, CARGO, WITHOUT WINCH, M985E1	2320-01-194-7031

Approved for public release; distribution is unlimited.

**LO 9-2320-279-12, December 1998, is changed as follows:**

1. Remove old pages and insert new pages as indicated below.
2. New or changed material is indicated by a vertical bar in the margin of the page.
3. Minor changes to illustrations are indicated by a miniature pointing hand.
4. Illustrations that are new or that have major revisions are indicated by a vertical bar adjacent to the illustration.

Remove Pages

1 thru 2 of 35  
5 thru 6 of 35  
31 thru 34 of 35

Insert Pages

1 thru 2 of 35  
5 thru 6 of 35  
31 thru 34 of 35

Copy of this lubrication order will remain with the equipment at all times; instructions contained herein are mandatory.

By Order of the Secretary of the Army:

ERIC K. SHINSEKI  
*General, United States Army*  
*Chief of Staff*

Official:

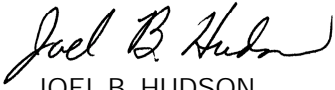
  
JOEL B. HUDSON  
*Administrative Assistant to the*  
*Secretary of the Army*  
0115514

DISTRIBUTION: To be distributed in accordance with the initial distribution requirements for (IDN) 380553, requirements for LO 9-2320-279-12.



## KEY

LUBRICANTS		CAPACITIES	EXPECTED TEMPERATURES			DESERT CONDITIONS	INTERVALS
			Above + 15°F (Above -9°C)	+40°F to -15°F (+4°C to -26°C)	+40°F to -50°F (+4°C to -46°C)		
OE/HDO (MIL-L-2104)	LUBRICATING OIL ICE, TACTICAL Engine W/O Filter (Mechanical)	28 Qt (27 L)	OE/ HDO-15W40	OE/ HDO-15W/40 or OEA See notes 1 and 7	OE/ HDO-15/W40 or OEA See note 2.	OE/ HDO 40	OC - On-conditions service when directed by AOAP laboratory  D - Daily (Operator)  W - Weekly  M - Monthly  Q - Quarterly (3 Months)  S - Semiannually (6 Months)  A - Annually  B - Biennially (2 Years)  0.5 - 500 Miles 1 - 1,000 Miles 1.5 - 1,500 Miles 2 - 2,000 Miles 3 - 3,000 Miles 6 - 6,000 Miles  12 - 12,000 Miles 20 - 20,000 Miles  60 Hr* 100 Hr* 200 Hr* 400 Hr* 800 Hr*
OEA (MIL-L-46167)	LUBRICATING OIL ICE, ARCTIC Engine W/Filter (Mechanical)	30 Qt (28.4 L)					
	LUBRICATING OIL ICE, TACTICAL Engine W/O Filter (Electronic)	28 Qt (27 L)	OE/ HDO-15W40	OE/ HDO-15W/40 or OEA See notes 1 and 7.	OE/ HDO-15/W40 or OEA	OE/ HDO 40	
	LUBRICATING OIL ICE, ARCTIC Engine W/Filter (Electronic)	30 Qt (28.4 L)					
	Transmission (Mechanical)	31Qt (29 L)	OE/ HDO-15W40	OE/ HDO-15W40	OE/ HDO-15W40		
	Transmission (Electronic) W/O Filter	37Qt (35 L)					
	W/Filter	38Qt (36 L)	OE/ HDO-15W40	OE/ HDO-15W40	OE/ HDO-15W40		
	Transfer Case	5 Qt (5 L)	OE/HDO 40	OEA/HDO 40 or OEA See note 3.	OEA/HDO 40 or OEA See note 3.		
OE/HDO (MIL-L-2104)	Hydraulic Reservoir M984E1 W/Filter	180 Qt (171 L)	OE/HDO-30 or OE/HDO-10 See note 4.	OE/HDO-10	OEA		
OEA (MIL-L-46167)	Models except M984E1 W/Filter	120 Qt (114 L)					
	Oil Can Points	As req	OE/HDO-30	OE/HDO-10	OEA		
GO (MIL-L-2105)	LUBRICATING OIL GEAR MULTIPURPOSE						
	Crane Rotation Gearbox (M977)	1 Pt (0.5 L)	GO-80W/90	GO-80W/90	GO-75		
	Crane Rotation Gearbox (M984E1, M985)	2.5 Pt (1.2 L)					
	Crane Hoist (M977, M985, M984E1)	1 Pt (0.5 L)					
	No. 1 Axle	See table 1	GO-85W/140	GO-85W/140 or GO-80W/90 See note 5.	GO-80W/90 or GO-75 See note 6.		
	No. 2 Axle and Power Divider	See table 1					
	No. 3 Axle and Power Divider	See table 1					
	No. 4 Axle	See table 1					
	Oil Lubed Wheel Bearings						
	Heavy Duty Winch Gearbox (M984, M984E1)	12 Qt (11 L)	GO-85W/140	GO-75 or GO-80W/90	GO-75		
	Self-Recovery Winch Gearbox	2 Qt (2 L)					
	DRY CLEANING SOLVENT SD-II (P-D-680)		SD-II All temperatures				
	ANTIFREEZE ETHYLENE GLYCOL INHIBITED, HEAVY DUTY, SINGLE PACKAGE (MIL-A-46153)	80 Qt (76 L)	Use above -50 F (-46 C)				
	ANTIFREEZE, ARCTIC-TYPE (MIL-A-11755)	80 Qt (76 L)	Use when extended periods of -40 F (-40 C) and below are encountered.				
	CORROSION INHIBITOR	2.4 Qt (2.28 L)					

\* Hours of operation as shown on vehicle hourmeter.

**KEY NOTES:**

1. OEA must be used when temperatures are consistently below 0°F (-18°C).
2. OE/HDO-15W/40 must be used when temperatures are consistently above 0°F (-18°C).
3. OE/HDO-40 must be used when temperatures are consistently above 0°F (-18°C).
4. OE/HDO-30 must be used only when temperatures are consistently above 60°F (16°C).
5. GO-85W/140 must be used when temperatures are consistently above 30°F (-1°C).
6. GO-80W/90 must be used when temperatures are consistently above -15°F (-26°C).
7. After changing to OEA, drain 1 pint of oil from Oil Sampling valve.

## KEY (CONT)

LUBRICANTS		CAPACITIES	EXPECTED TEMPERATURES			DESERT- CONDITIONS	INTERVALS
			Above +15°F (Above -9°C)	+40°F to -15°F (+4°C to -26°C)	+40°F to -50°F (+4°C to -46°C)		
GAA (MIL-G-10924)	GREASE, AUTOMOTIVE AND ARTILLERY	As req	GAA All temperatures			For arctic operation, refer to FM 9-207.	
	Propeller Shafts and U-Joints						
	Crane Pivot Points and Sheave						
	Boom Wear Pads						
	Crane Rotation Bearing						
	Trunnion Bearings						
	Brake Cam Slack Adjuster						
	Spring Eye Pins						
	Self-Recovery Winch, Cable Tensioner Rollers and Pivots						
	Cable Guide Rollers						
	Pintle Hook						
	Wheel Bearings						
	Steering System, Linkages, Trunnions, U-Joints, Tie Rods						
	Tire Davit						
	Engine Throttle Air Cylinder						
	Fifth Wheel Plate						
	Fifth Wheel Ramp						
	Slewing Cylinders (M983 Only)						
	Crane Control Linkages (M983 Only)						
	Tanker Reel Support Bearings (M978 Only)						
Retrieval System (M984E1 Only)							
Wrecker Body Roll Mounts (M984E1 Only)							
Heavy-Duty Winch, Mounts (M984E1 Only)							
Winch Cable Guide (M984E1 Only)							
Fairlead Assembly (M984E1 Only)							
Wax, Paste 7930-00-985-6750		Desert Conditions					

**Table 1. Axle Capacities**

Vehicle Model		Axle Number			
		1	2	3	4
All	Axle Model No. Quarts (Liters)	RS480 17.5 (17)	DS480-P 21.5 (20)		
M977, M978, M985, M985E1	Axle Model No. Quarts (Liters)			DS480-P-CTD 21 (20)	RS480-CTD 16.5 (16)
M983	Axle Model No. Quarts (Liters)			DS480-P 24 (23)	RS480 15.5 (15)
M984	Axle Model No. Quarts (Liters)			DT581-P 21.5 (20)	RT581 18 (17)
M984E1	Axle Model No. Quarts (Liters)			DS650-P 21.5 (20)	RS650-P 22 (21)

Table 2. Total Man-hours\*

	OC	D	W	M	Q	A	1.5/Q	3/S	6/A	12/B	20/B	M/ 100HR	Q/ 250HR	S/ 100HR	S/ 400HR	S/ 1250HR	A/ 800HR	A/ 1250HR
TRUCK, CARGO, W/WINCH: M977, M985	2.5	0.5			0.6	0.5	1.8	2.5	1.2	3.8	2.6	0.1	1.0		0.2	0.2	1.0	0.6
TRUCK, CARGO, W/O WINCH: M977, M985	2.5	0.5			0.3		1.8	2.5	1.2	3.8	2.6	0.1	1.0		0.2	0.2	1.0	0.6
TRUCK, TANK, FUEL, W/WINCH: M978	2.5	0.5			0.6	0.5	1.8	2.5	1.2	3.8	2.6	0.7			0.2		1.0	
TRUCK, TANK, FUEL, W/O WINCH: M978	2.5	0.5			0.3		1.8	2.5	1.2	3.8	2.6	0.7			0.2		1.0	
TRUCK, TRACTOR W/CRANE: M983	2.5	0.5	0.9		0.6	0.5	1.8	2.5	1.2	3.8	2.6			1.1	0.2		1.0	
TRUCK, TRACTOR W/O CRANE: M983	2.5	0.5	0.9		0.6	0.5	1.8	2.5	1.2	3.8	2.6				0.2		1.0	
TRUCK, WRECKER- RECOVERY: M984 [	2.5	0.5			0.8	1.0	1.8	2.5	1.2	3.8	2.6				0.2		1.0	
TRUCK, WRECKER- RECOVERY: M984E1	2.5	0.5		0.3	0.6	1.0	2.1	2.5	1.2	3.8	2.6	0.2	1.0		0.2	0.2	1.0	0.6
TRUCK, CARGO W/WINCH: M985E1 [[]	2.5	0.5		0.2	0.6	0.5	1.8	2.5	1.2	3.8	2.6				0.2		1.0	
TRUCK, CARGO W/O WINCH: M985E1 [[]	2.5	0.5			0.3		1.8	2.5	1.2	3.8	2.6				0.2		1.0	

\* The man-hours shown have been established on an individual basis and, accordingly, are not applicable at maintenance facilities where production line methods are employed.

[ Figures do not include total man-hours to service HIAB model 8109 crane. For model 8109 figures refer to LO 9-2320-355-20.

[[] Figures do not include total man-hours to service HIAB model 8108 crane. For model 8108 figures refer to LO 9-2320-354-20.

**LUBRICANT · INTERVAL**

**INTERVAL · LUBRICANT**

**FRONT**

**No. 1 Axle Differential**

Check and fill. (O)

GO 3/S

Drain and refill. (O)  
(See notes 1, 6a, 6c, and view A.)

GO 20/B

**Spring Pivots**

Lubricate. (1 fitting per spring) (O)  
(See note 2g and view F.)

GAA 1.5/Q

**No. 1 Propeller Shaft and Universal Joints**

Lubricate. (3 fittings) (O)  
(See notes 2a, 2b, 2c, 2d, and view D.)

GAA 3/S

**No. 2 Axle Differential and Power Divider**

Check and fill. (O)  
Drain and refill. (O)  
(See notes 1, 6a, 6b, 6c, 6e, and views B and C.)

GO 3/S

GO 20/B

**No. 2 Propeller Shaft and Universal Joints**

Lubricate. (3 fittings) (O)  
(See notes 2a, 2b, 2c, 2d and view D.)

GAA 3/S

**Wrecker Body Support Assembly (M984E1)**

Lubricate. (2 fittings) (O)  
(See note 2a and views CA and CB.)

GAA 1.5/Q

**No. 3 Axle Differential and Power Divider**

Check and fill. (O)  
Drain and refill. (O)  
(See notes 1, 6a, 6b, 6d, 6e, and views B and C.)

GAA 3/S

GO 20/B

**Brake Camshaft and Slack Adjuster**

Lubricate. (2 fittings) (O)  
(See note 2a and view G.)

GAA 1.5/Q

**Mirror Assembly Swivel Joints**

GAA Apply light coating of grease. (O)  
(See view CK.)

**Front Wheel Bearings**

GAA Remove, clean, and repack. (O)  
(See note 2e, and view L.)

**No. 3 Propeller Shaft and Universal Joints**

GAA Lubricate. (3 fittings) (O)  
(See notes 2a, 2b, 2c, 2d, and view D.)

**Brake Camshaft and Slack Adjuster**

GAA Lubricate. (2 fittings) (O)  
(See note 2a and view G.)

**Spring Pivots**

GAA Lubricate. (1 fitting per spring) (O)  
(See note 2g and view F.)

**No. 4 Propeller Shaft and Universal Joints**

GAA Lubricate. (3 fittings) (O)  
(See notes 2a, 2b, 2c, 2d, and view D.)

**No. 4 Axle Differential**

GO Check and fill. (O)

GO Drain and refill. (O)  
(See notes 1, 6a, 6d, 6e, and view A.)

**Pintle Hook**

GAA Lubricate. (3 fittings) (O)  
(See note 2f and view E.)

**Self-Guided Coupler (M977-ICBT)**

GAA Lubricate. (5 fittings) (O)  
(See notes 2a, 7, and view E.)

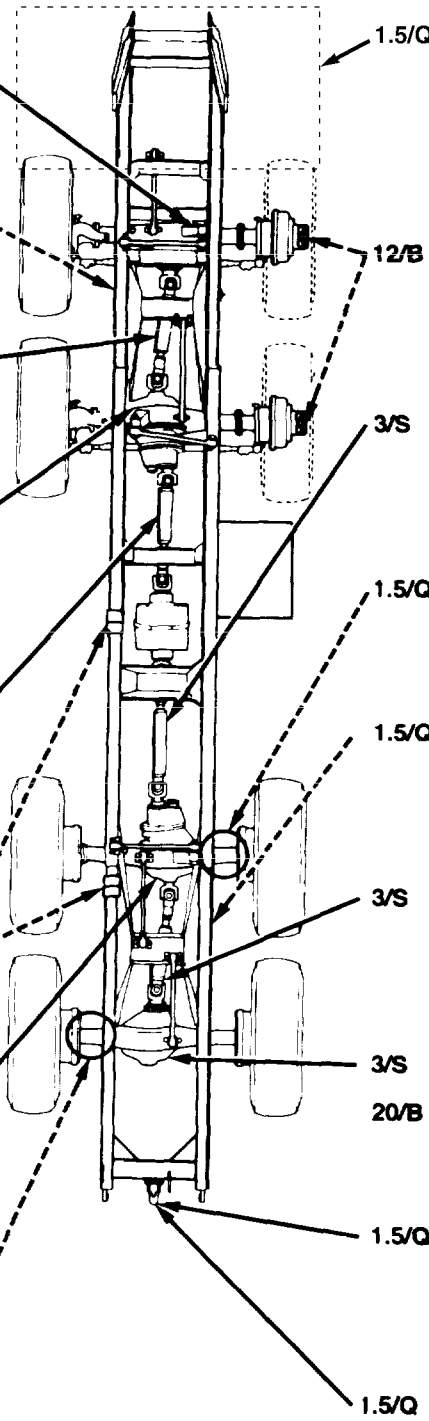

**(TOP VIEW)  
CHASSIS**

FRONT

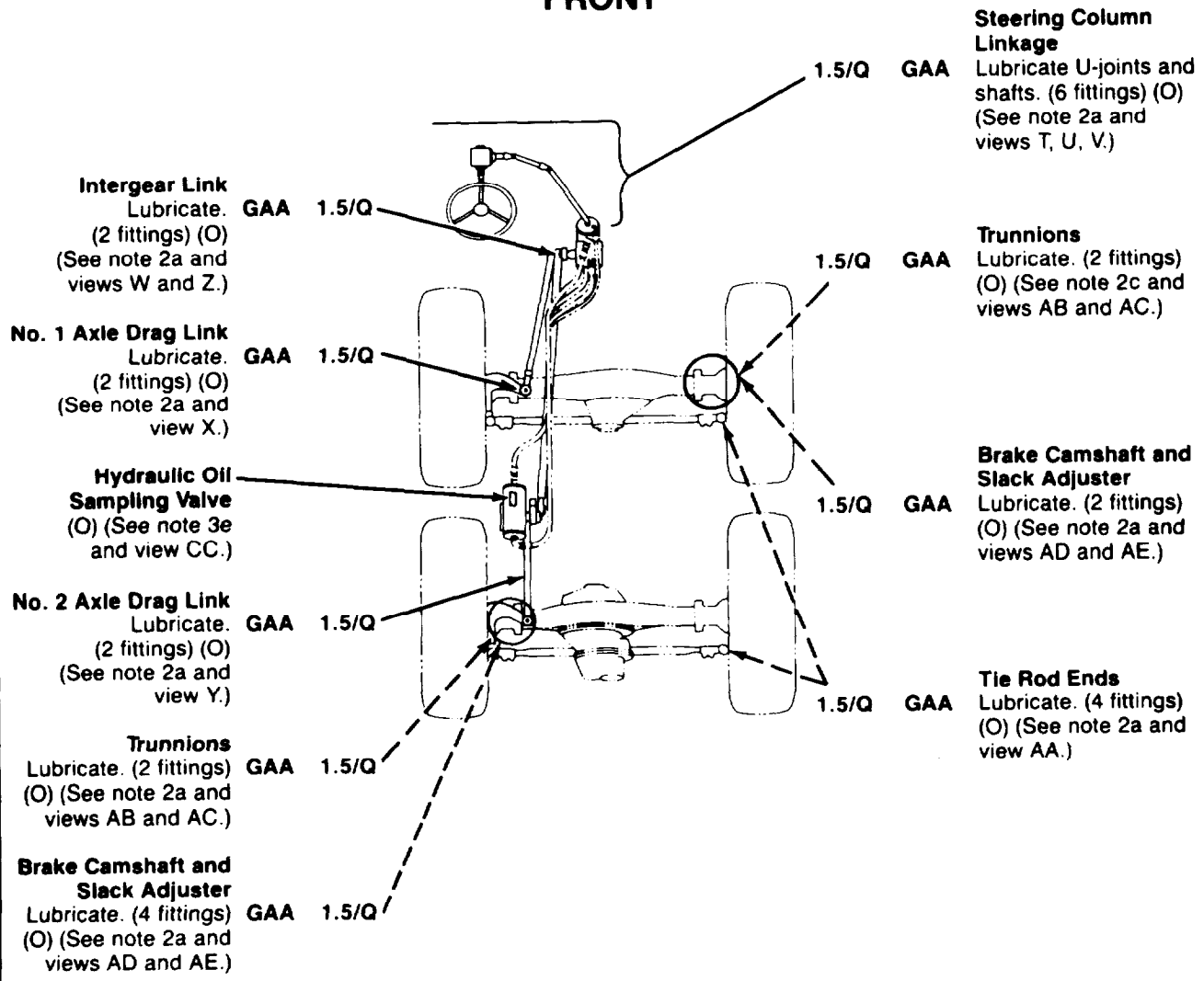

**Intergear Link**  
Lubricate. (2 fittings) (O)  
(See note 2a and views W and Z.)

**No. 1 Axle Drag Link**  
Lubricate. (2 fittings) (O)  
(See note 2a and view X.)

**Hydraulic Oil Sampling Valve**  
(O) (See note 3e and view CC.)

**No. 2 Axle Drag Link**  
Lubricate. (2 fittings) (O)  
(See note 2a and view Y.)

**Trunnions**  
Lubricate. (2 fittings) (O)  
(See note 2a and views AB and AC.)

**Brake Camshaft and Slack Adjuster**  
Lubricate. (4 fittings) (O)  
(See note 2a and views AD and AE.)

**Steering Column Linkage**  
Lubricate U-joints and shafts. (6 fittings) (O)  
(See note 2a and views T, U, V.)

**Trunnions**  
Lubricate. (2 fittings) (O)  
(See note 2c and views AB and AC.)

**Brake Camshaft and Slack Adjuster**  
Lubricate. (2 fittings) (O)  
(See note 2a and views AD and AE.)

**Tie Rod Ends**  
Lubricate. (4 fittings) (O)  
(See note 2a and view AA.)

(TOP VIEW)  
**STEERING SYSTEM**

FRONT

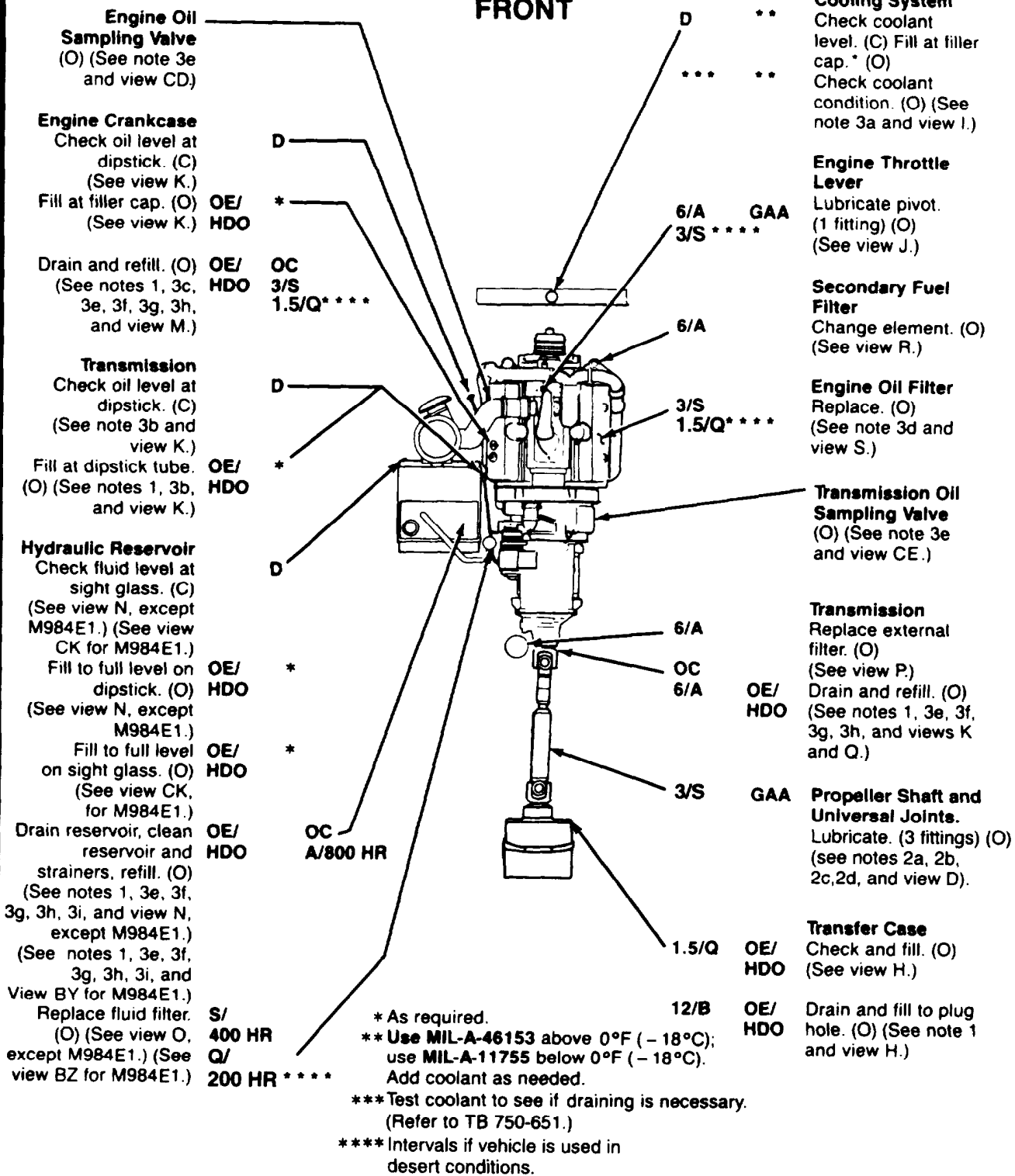

(TOP VIEW)

**ENGINE, TRANSMISSION, TRANSFER CASE, COOLING SYSTEM, AND HYDRAULIC RESERVOIR**

INTERVAL • LUBRICANT

FRONT

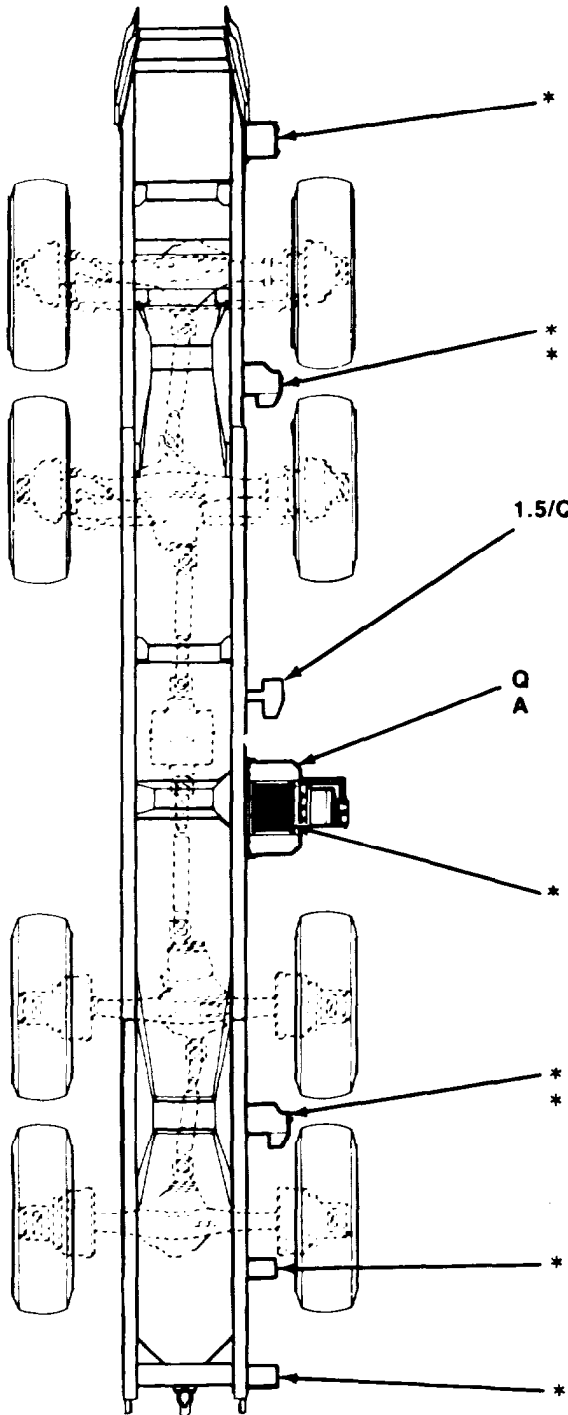

(TOP VIEW)

\* GAA **Front Cable Guide**  
Lubricate. (4 fittings) (O)  
(See note 2a and view AF.)

\* GAA **Front Cable Tensioner**  
Lubricate rollers. (3 fittings) (O)  
\* OE/HDO Lubricate pivots and pressure rollers  
with oilcan. (O)  
(See note 2a and view AG.)

1.5/Q GAA **Vise Assembly (M984E1)**  
OE/HDO Lubricate. (1 fitting) (O)  
Lubricate vise adjustment screw with  
oilcan.  
(See view BT.)

Q GO **Self-Recovery Winch**  
A GO Check and fill gearbox. (O)  
Drain and refill drum. (O)  
(See notes 1, 5c, and views AH and  
AI.)

\* OE/HDO **Self-Recovery Winch Cable**  
Unreel, clean, and oil. (C)

\* GAA **Rear Cable Tensioner**  
OE/HDO Lubricate rollers. (3 fittings) (O)  
Lubricate pivots and pressure rollers  
with oilcan. (O)  
(See note 2a and view AG.)  
(Except M984E1)

\* GAA **Small Cable Guide**  
Lubricate roller. (1 fitting) (O)  
(See note 2a and view AJ.)  
(M978, M983, M984)

\* GAA **Rear Cable Guide**  
Lubricate roller. (4 fittings) (O)  
(See note 2a and view AK.)  
(Except M984E1)

\* As required.

SELF-RECOVERY WINCH

LUBRICANT • INTERVAL

INTERVAL • LUBRICANT

**Gears of Reel and Ratchet**  
Apply light coating of grease. (O)

**Tire Davit at Pivot Point**  
Clean and apply light coating of grease.

**Bushings of Crank and Ratchet Shaft**  
Lubricate with oilcan. (O)

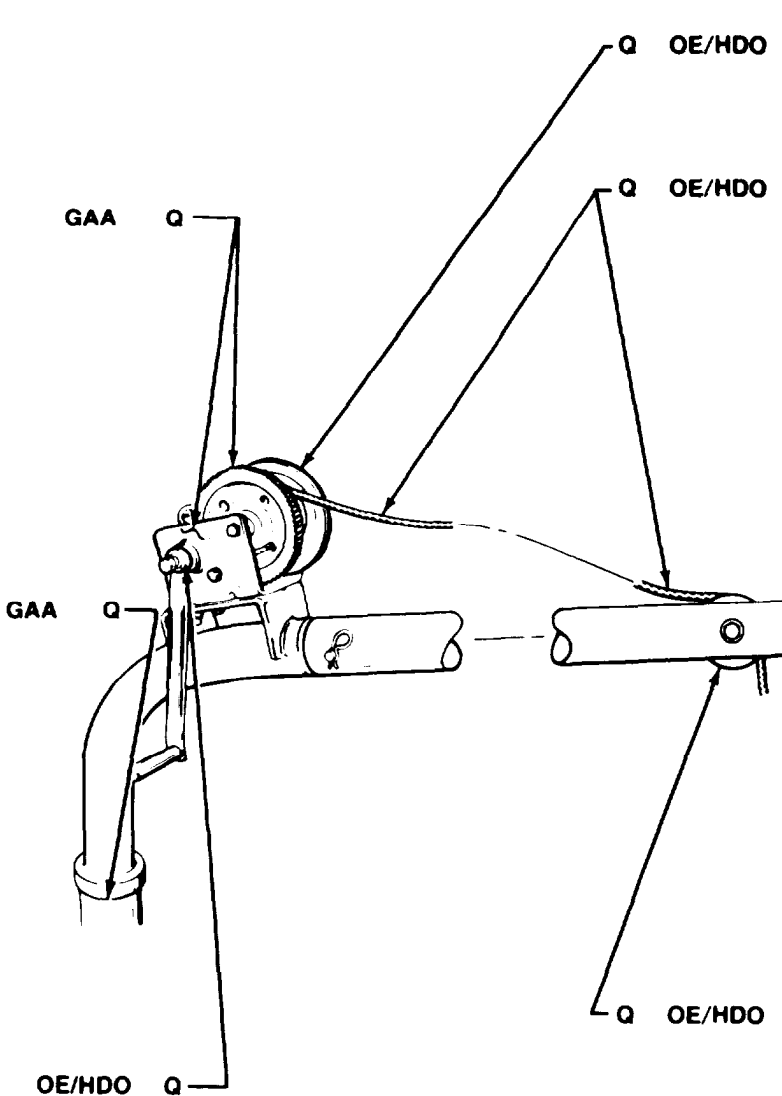

**Reel and Reel Shaft**  
Lubricate with oilcan. (O)

**Cable**  
Unreel, clean, and apply light coating of oil. (O)

**Pulley**  
Lubricate with oilcan. (O)

### SPARE TIRE DAVIT



**LUBRICANT • INTERVAL**

**INTERVAL • LUBRICANT**

**Deadman Control Reel**

Apply oil to ratchet mechanism with oilcan. (O)  
(See view AM.)

OE/ HDO M/ 100 HR

M/ 100 HR

GAA

**Fuel Hose Reels**

Lubricate crank handle bearings. (1 fitting on each reel) (O)  
(See view AL.)

M/ 100 HR

OE/ HDO

Apply oil to axles of hose guide rollers with oilcan. (O) (See view AL.)

M/ 100 HR

GAA

Apply light coating of grease to rewind gears. (O) (See view AL.)

**Static Discharge Line Reels**

Apply oil to pawl and ratchet mechanism with oilcan. (O)  
(See view AN.)

M/ 100 HR

OE/ HDO

**Pump Engagement Lever**

Oil pivot points and sliding points of lever and linkage with oilcan. (O)  
(See view AP.)

OE/ HDO M/ 100 HR

M/ 100 HR

OE/ HDO

**Emergency Control Valve Lever**

Oil pivot points and sliding points of lever and linkage. (O)  
(See view AO.)

**CAUTION**

Do not lubricate. May result in fuel contamination and equipment damage.

**FUEL SERVICE MODULE**

**INTERVAL • LUBRICANT**

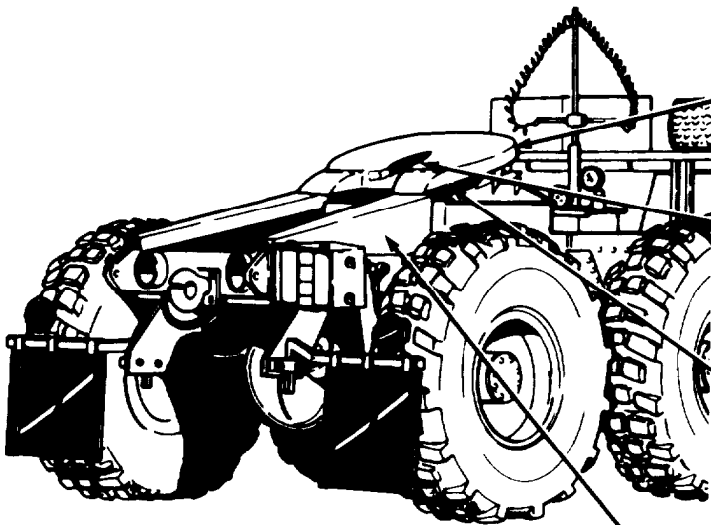

**M983 W/WINCH - RIGHT SIDE**

W GAA **Fifth Wheel Plate**  
Clean and coat lightly overall with grease. (C)  
(See note 4.)

W GAA **Fifth Wheel Jaws**  
Clean and coat with grease. (O)  
(See view AR.)

W OE/HDO **Fifth Wheel Locking Linkage and Lube Fittings**  
Oil all pivot points springs and locking linkage. (O)  
(See note 4 and view AT.)

W GAA  
Lubricate. (12 fittings)  
(O) (See note 4 and views AQ, AR, AS, and AT.)

W GAA **Fifth Wheel Approach Ramp**  
Clean and coat lightly with grease. (C)  
(See note 4.)

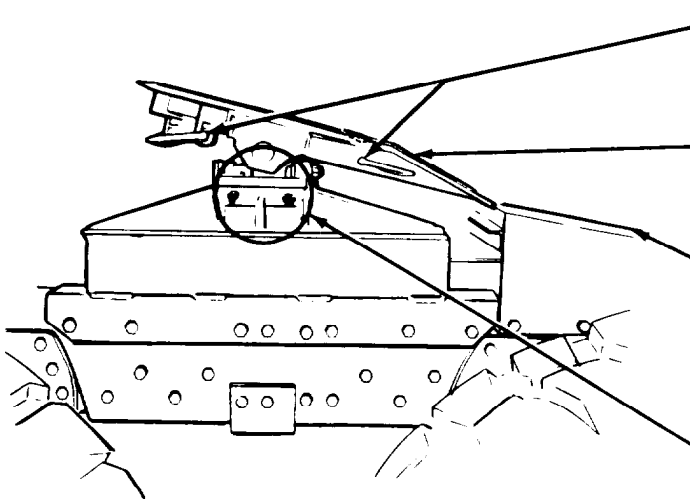

**M983 W/WINCH - LEFT SIDE**

W GAA **Fifth Wheel Plate**  
Clean and coat lightly overall with grease. (C)  
(See note 4.)

W GAA **Fifth Wheel Jaws**  
Clean and coat with grease. (O) (See view AR.)

W GAA **Fifth Wheel Approach Ramp**  
Clean and coat lightly with grease. (C)  
(See note 4.)

W OE/HDO **Fifth Wheel Locking Linkage and Lube Fittings**  
Oil all pivot points, springs, and locking linkage. (O) (See note 4 and view AT.)

W GAA  
Lubricate. (12 fittings)  
(O) (See note 4 and views AQ, AR, AS, and AT.)

**FIFTH WHEEL**

**LUBRICANT • INTERVAL**

**INTERVAL • LUBRICANT**

**Heavy-Duty Winch Cable**  
Unreel, clean, and oil after each use. (C)

**Drum Gearbox**  
Check level and fill as required. (O)  
Drain and refill. (O)  
(See notes 1, 5b, and views BH and BI.)

OE/HDO \*

GO

GO

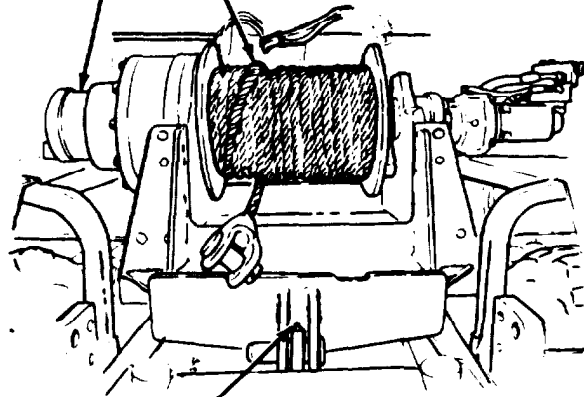

**Rear Attachment Fitting**  
Lubricate. (1 fitting) (O)

GAA

M



**Heavy-Duty Snatch Block**  
Lubricate center shaft after each use. (1 fitting) (O) Lubricate swivel and safety latch with oil can. (C)

\*\* GAA  
M OE

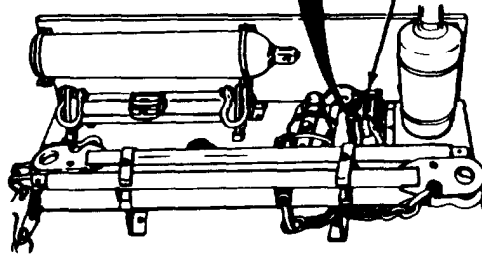

\* As required.  
\*\* Lubricate center shaft after each use.

**HEAVY-DUTY (RECOVERY) WINCH (M984)**

FRONT

Heavy-Duty Winch Cable  
Clean and oil after each use. (C)

OE/  
HDO

\*

Heavy-Duty Winch Motor  
(Self-lubricated with hydraulic oil. See note 5d.)

GAA

1.5/Q

Winch Mounts  
Lubricate. (2 fittings) (O)  
(See note 2a.)

Cable Guide Assembly  
Lubricate. (1 fitting on pulley hub) (O)  
(See note 2a and view CF.)

\*\*  
GAA

1.5/Q

Fairlead Pivot  
Lubricate pivot point with oilcan. (C)  
(See view CG.)

OE/  
HDO

1.5/Q

Fairlead/Tensioner  
Lubricate. (1 fitting) (O)  
(See note 2a and view CG.)

GAA

1.5/Q

1.5/Q

GO

\*

A

GO

Drum Gearbox  
Check oil level at check hole. Fill at fill hole. (See view BU.)  
Drain and refill. (O)  
(See note 1, 5b, and view BU.)

Fairlead/Tensioner Sheave  
Lubricate. (1 fitting on fairlead tensioner) (O)  
(See view CG.)

OE/  
HDO

\*

Heavy-Duty Snatch Block  
Lubricate center shaft after each use. (1 fitting) (O)  
Lubricate locking jaws and pin with oilcan. (C)

GAA

\*

OE/  
HDO

M

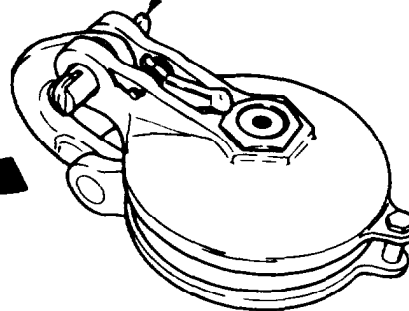
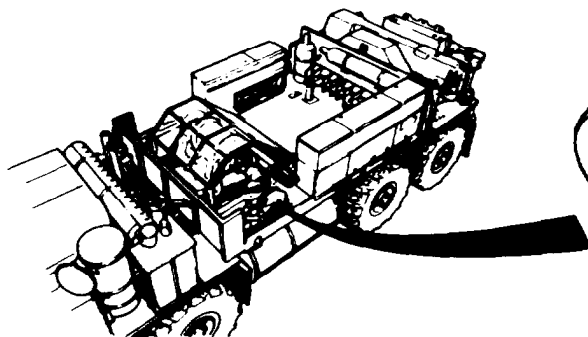

\* As required.  
\*\* Located under equipment body.

HEAVY-DUTY (RECOVERY) WINCH (M984E1)

**LUBRICANT • INTERVAL**

**INTERVAL • LUBRICANT**

**Lift Cylinder Pivot**  
Lubricate both ends of lift cylinders. (8 fittings) (O)  
(See note 2a and views AY and BA.)

**Mast Pivot**  
Lubricate both ends of mast. (4 fittings) (O)  
(See note 2a and view AW and AX.)

**Erection Cylinder Pivot**  
Lubricate both ends of erection cylinders. (8 fittings) (O)  
(See note 2a and views AZ and BB.)

**Crane Hoist Drive**  
Check oil level at fill plug. Add oil to level of fill hole. (O)  
(See view BD.)

**Crane Control Levers**  
Lubricate all pivots of control levers with oilcan. (O)  
(See view CH.)

**Swing Drive Gearbox**  
Check oil level at overflow hole. (O)  
(See view BG.)

**Rotation Gear and Pinion Teeth**  
Coat external teeth of rotation gear lightly with grease. (O)  
(See notes 5a, 5e, and view AV.)

\*Coat external teeth of rotating gear lightly with paste wax. (O).  
(See notes 5a, 5e, 5f, and view AV.)

GAA Q/ 250 HR

GAA Q/ 250 HR

GAA Q/ 250 HR

GO A/ 1250 HR

OE/ HDO M/ 100

GO A/ 1250 HR

GAA Q/ 250 HR

Q/ 250 HR

Q/ 250 HR

Q/ 250 HR

Q/ 250 HR

Q/ 250 HR

Q/ 250 HR

Q/ 250 HR

Q/ 250 HR

S/ 1250 HR

GAA

GAA

OE/ HDO

OE/ HDO

GAA

OE/ HDO

GAA

GAA

**Boom Wear Pads**  
Clean sliding surfaces of boom wear pads and lubricate by coating with grease. (O) (See note 5a.)

**Boom Nose Sheave**  
Lubricate bushing. (1 fitting) (O)  
(See note 2a and view BF.)

Unreel, clean, and oil cable (O).

**Hook Block Clevis**  
Lubricate pivot point of hook block clevis with oilcan. (O)  
(See view BE.)

**Hook Block Sheave**  
Lubricate bushing. (1 fitting) (O) (See note 2a and view BE.) (M985)

**Hook Block Clevis**  
Lubricate pivot points on hook block with oilcan. (O) (M977)

**Turntable Bearing**  
Raise mast until lube fitting comes into view. Turn and lubricate turntable every 90° until you have turned the turntable 360°, then rotate crane a full 360° to spread lubricant. (1 fitting) (O) (See note 2a and view BC.)

**Outrigger Bottom Plate**  
Clean sliding surfaces of outrigger bottom plate and lubricate with grease. (O) (See note 5a and view AU.)

**Hydraulic Fluid Filter**  
Change element. (O)  
(See view CE.)

\*For vehicle used in desert conditions.

**M977 AND M985 CRANE**

**LUBRICANT • INTERVAL**

**INTERVAL • LUBRICANT**

**Lift Cylinder Pivot**  
Lubricate both ends of lift cylinders. (8 fittings) (O) (See note 2a and views BN and BO.)

GAA Q/ 250 HR

**Tension Link Pivot**  
Lubricate both ends of tension links. (8 fittings) (O) See note 2a and views BJ and BK.)

GAA Q/ 250 HR

**Outrigger Bottom Plate**  
Clean sliding surfaces of outrigger bottom plate and lubricate with grease. (O) (See note 5a.)

GAA Q/ 250 HR

**Hydraulic Fluid Filter**  
Change element. (O) (See view BS.)

S/ 1250 HR

**Mast Pivot**  
Lubricate both ends of mast. (4 fittings) (O) See note 2a and views BL and BM.)

GAA Q/ 250 HR

**Erection Cylinder Pivot**  
Lubricate lower end of erection cylinder. (2 fittings) (O) (See note 2a and view BP.)

GAA Q/ 250 HR

**Swing Drive Gearbox**  
Check oil level at overfill plug. Add oil to level of overfill hole. (O) (See view BG.)

GO A/ 1250 HR

**Crane Control Levers**  
Lubricate all pivots of control levers with oilcan. (O) (See view CJ.)

OE/ HDO M/ 100 HR

\*Coat external teeth of rotating gear lightly with paste wax. (O). (See notes 5a, 5e, 5f, and view AV.)

Q/ 250 HR

**GAA Boom Wear Pads**  
Clean sliding surfaces of boom wear pads and lubricate by coating with grease. (O) (See note 5a.)

Q/ 250 HR

**GAA Boom Nose Sheave**  
Lubricate bushing. (2 fittings) (O) (See note 2a and view BF.)

Q/ 250 HR

**OE/ HDO Hoist Cable.** Unreel, clean and oil.

Q/ 250 HR

**OE/ HDO Hook Block Clevis**  
Lubricate pivot point of hook block clevis with oilcan. (O) (See view BE.)

Q/ 250 HR

**GAA Hook Block Sheave**  
Lubricate bushing. (2 fittings) (O) (See note 2a and view BR.)

A/ 1250 HR

**GO Crane Hoist Drive**  
Check oil level at fill plug. Add oil to level of fill hole. (O) (See view BD.)

M/ 100 HR

**OE/ HDO Crane Control Levers**  
Lubricate all pivots of control levers with oilcan. (O) (See view CF.)

Q/ 250 HR

**GAA Turntable Bearing**  
Raise mast until lube fitting comes into view. Turn and lubricate turntable every 90° until you have turned the turntable 360°, then rotate crane a full 360° to spread lubricant. (1 fitting) (O) (See note 2a and view BC.)

Q/ 250 HR

**OE/ HDO Hook Block Lockpin**  
Lubricate pin with oilcan. (O) (See view BQ.)

Q/ 250 HR

**GAA Rotation Gear and Pinion Teeth**  
Coat external teeth of rotation gear lightly with grease. (O) (See note 5a, 5e, and view AV.)

**M984E1 CRANE**

\*For vehicle used in desert conditions.

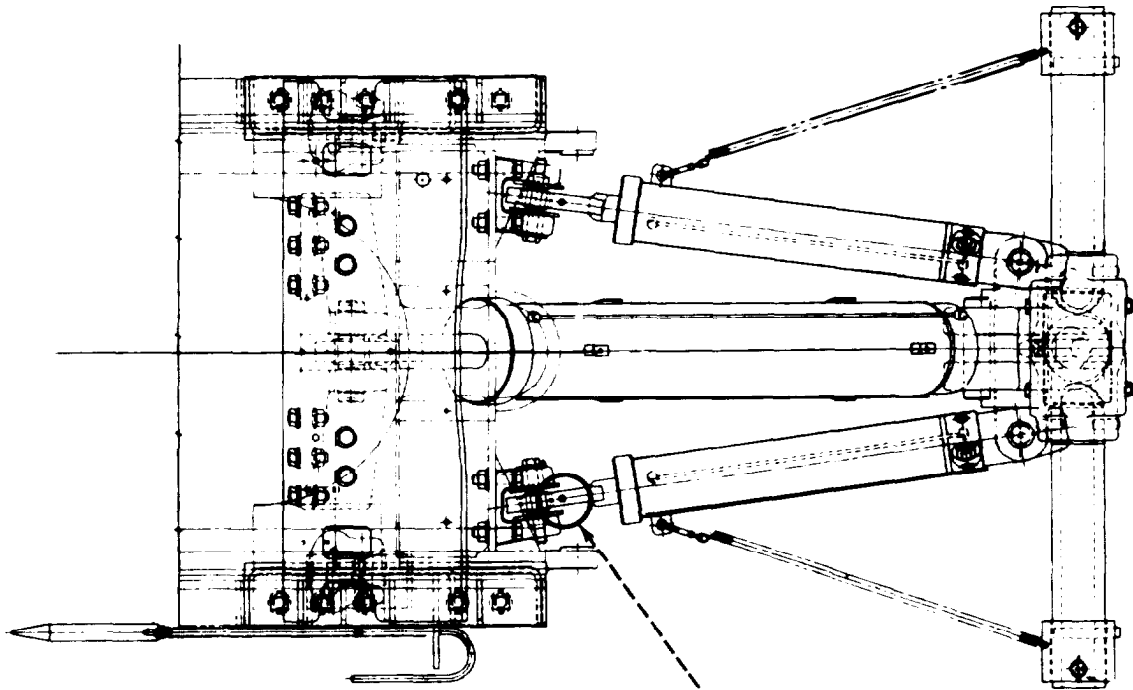

**Retriever Assembly  
Lube Points**  
Lubricate. (2 fittings) (O)  
(See view BW.)

1.5Q GAA

**Retriever Assembly  
Lube Point**  
Lubricate. (1 fitting) (O)  
(See view BV.)

1.5/Q GAA

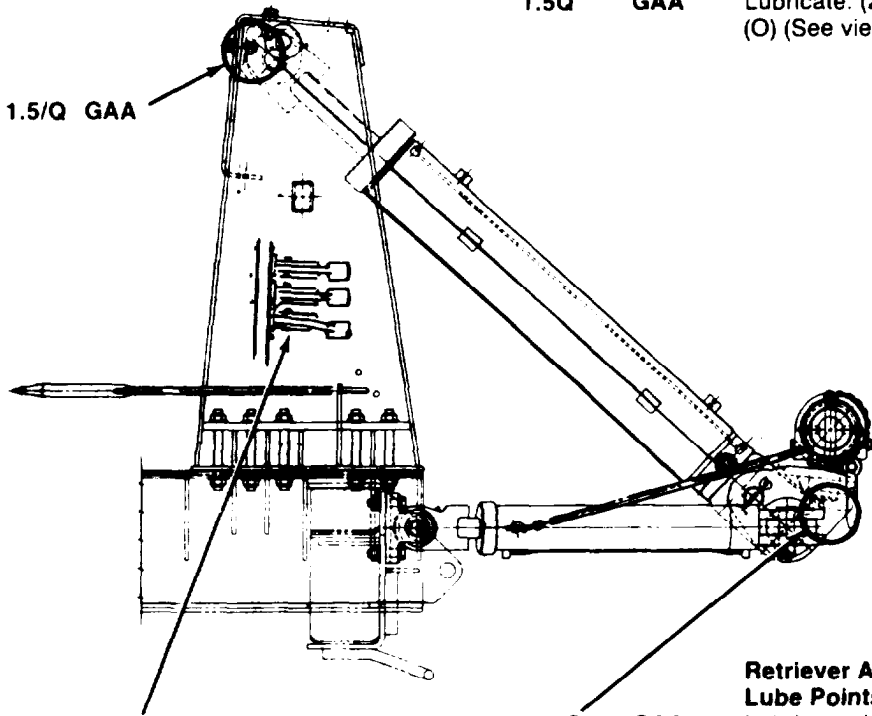

**Retriever Assembly  
Lube Points**  
Lubricate. (1 fitting) (O)  
(See view BX.)

1.5/Q GAA

**Retriever Assembly  
Levers**  
Lubricate all pivots  
of control levers  
with oil can. (O)  
(See view CG.)

OE/ S/  
HDO 100 HR

## RETRIEVER ASSEMBLY (M984E1)

**A**

CHECK AND FILL

DRAIN

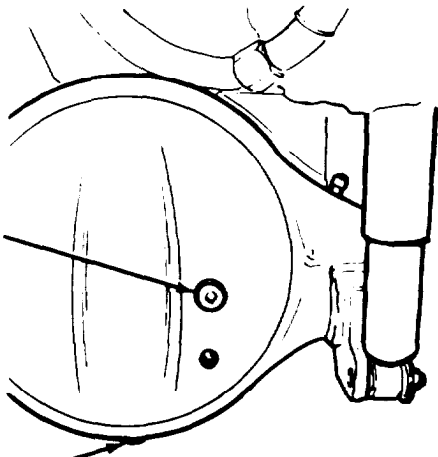

**NO. 1 AND 4 AXLE DIFFERENTIALS**

**B**

CHECK AND FILL

DRAIN

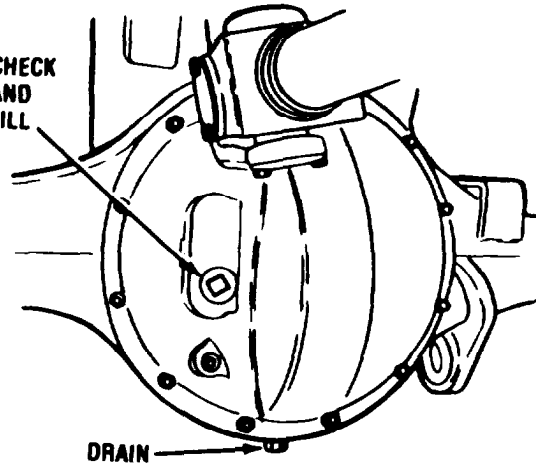

**NO. 2 AND 3 AXLE DIFFERENTIALS**

**C**

FILL PLUG

DRAIN PLUG AND FILTER SCREEN

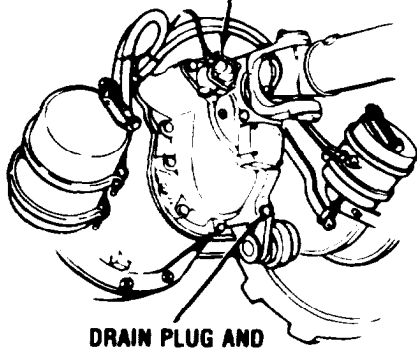

**POWER DIVIDER, NO. 2 AND 3 AXLES**

**D**

SLEEVE YOKE SEAL

U-JOINT CROSS FITTING

SPLINE FITTING

U-JOINT CROSS FITTING

PRESSURE RELIEF HOLE

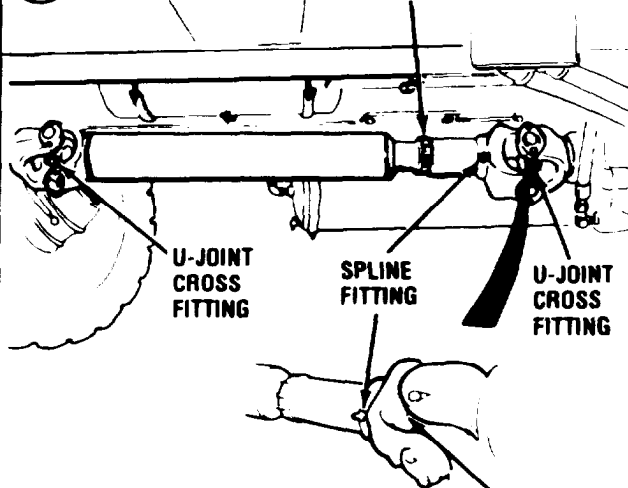

**TYPICAL PROPELLER SHAFT**

**E**

LUBE (FITTING MAY BE ON BOTTOM)

LUBE

LUBE FITTINGS (5 PLACES)

LUBE

OIL CAN POINT

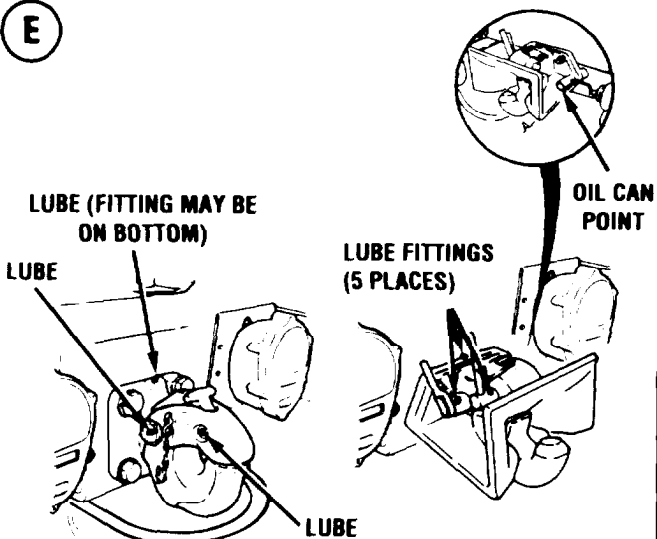

**PINTLE HOOK/Self-GUIDED COUPLER (M1977-CBT)**

**F**

LUBE

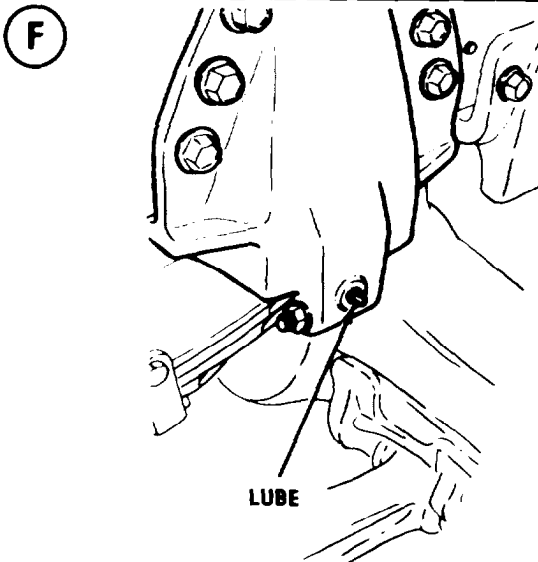

**SPRING PIVOT**



G

SLACK  
ADJUSTER  
LUBE  
FITTING

BRAKE  
CAMSHAFT  
LUBE  
FITTING

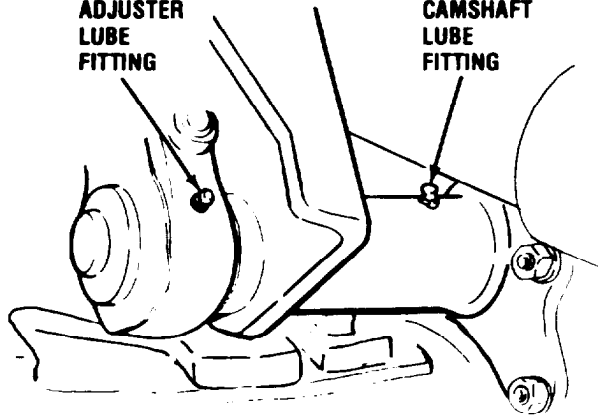

**NO. 3 AND 4 AXLE BRAKE CAMSHAFT AND  
SLACK ADJUSTER**

H

CHECK  
AND  
FILL  
PLUG

DRAIN PLUG

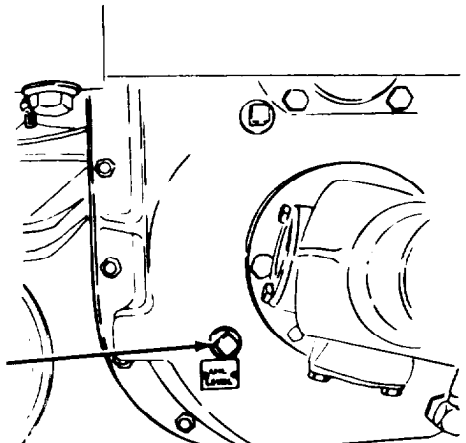

**TRANSFER CASE**  
*(Under vehicle, looking forward)*

I

TURN  
TO  
REMOVE

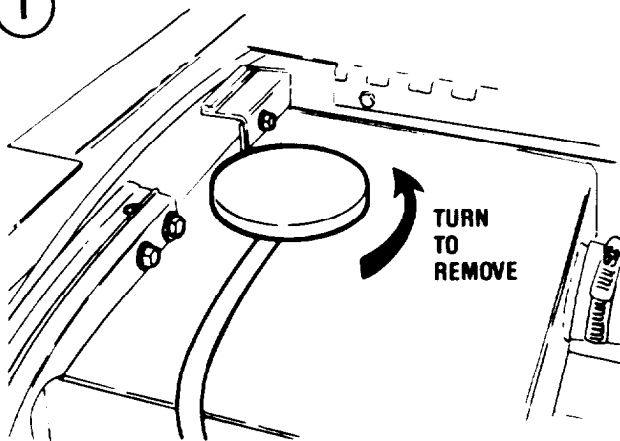

**WARNING**

Remove cap slowly  
when engine is hot.

**RADIATOR FILLER CAP**

J

LUBE

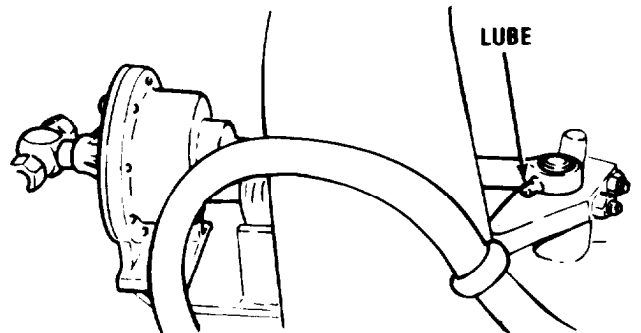

**ENGINE THROTTLE LEVER**

K

CRANKCASE  
FILLER  
CAP

TRANSMISSION  
CHECK  
AND FILL

ENGINE  
DIPSTICK



**LEFT SIDE OF ENGINE**

L

APPLY  
GREASE

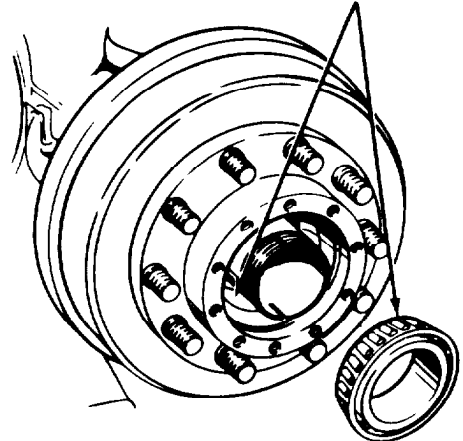

**FRONT WHEEL BEARING**

M

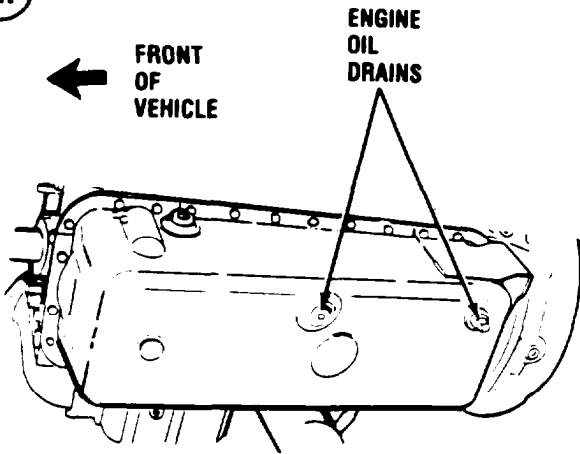

ENGINE CRANKCASE DRAIN

N

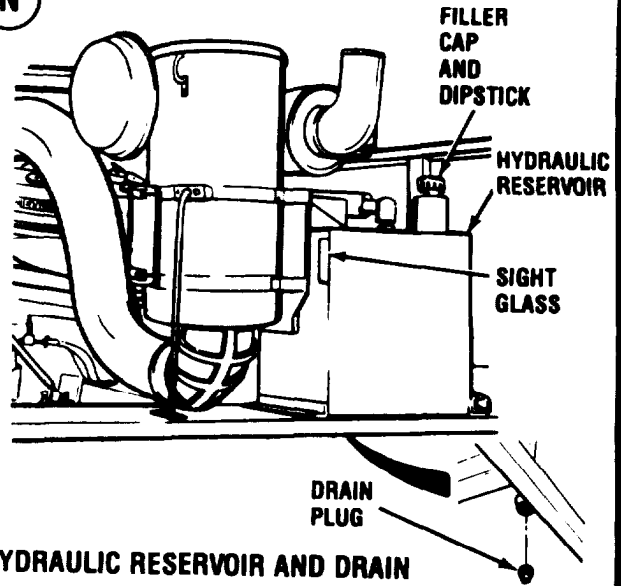

HYDRAULIC RESERVOIR AND DRAIN

O

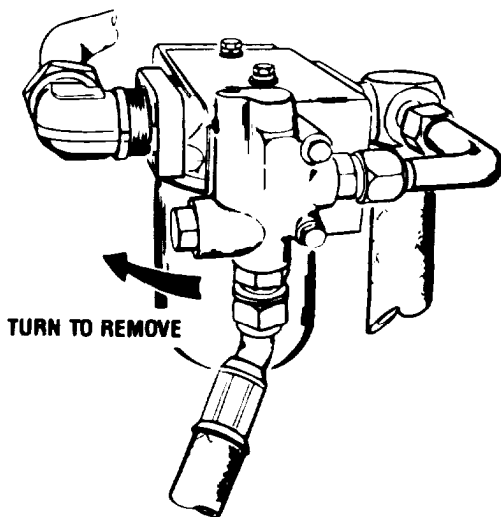

HYDRAULIC OIL FILTER

P

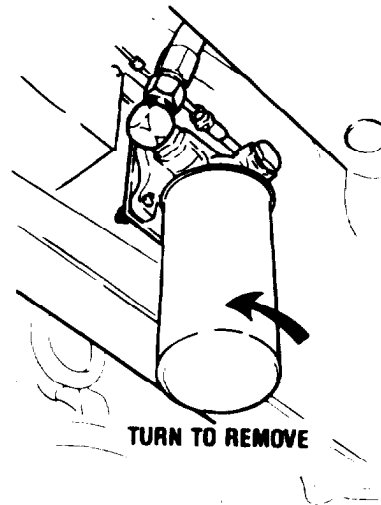

TRANSMISSION EXTERNAL FILTER  
*(Inside left frame rail, behind No. 2 axle)*

Q

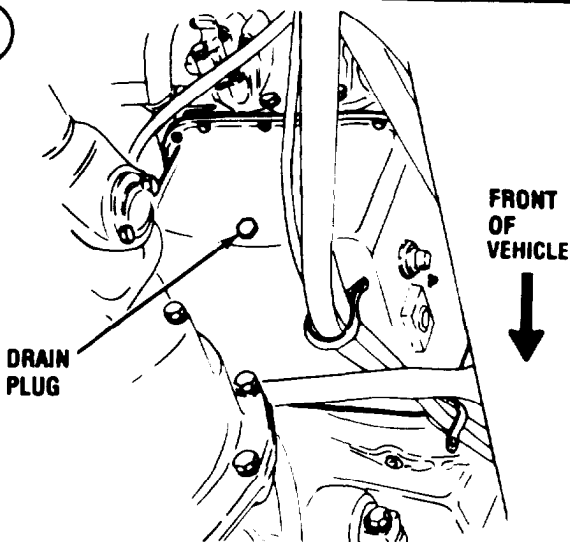

TRANSMISSION OIL PAN

R

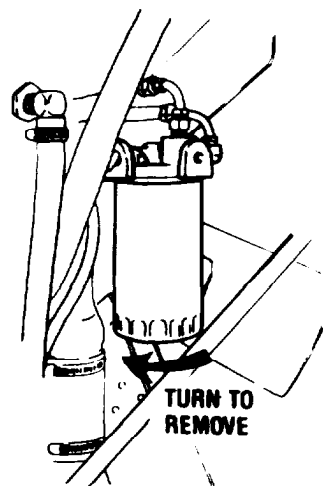

SECONDARY FUEL FILTER

S

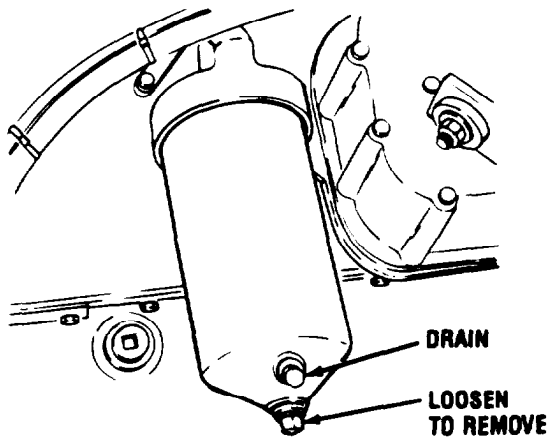

ENGINE OIL FILTER

T

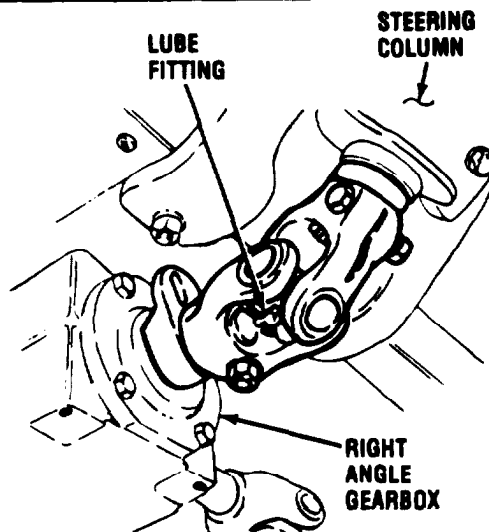

U-JOINT—STEERING COLUMN TO RIGHT ANGLE GEARBOX

U

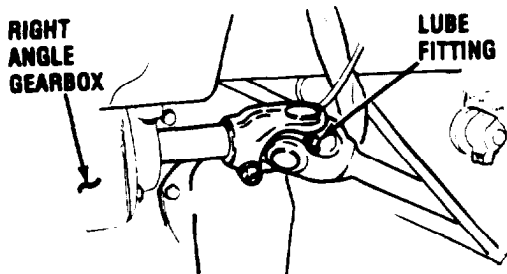

U-JOINT—RIGHT ANGLE GEARBOX TO FIRST STEERING SHAFT

V

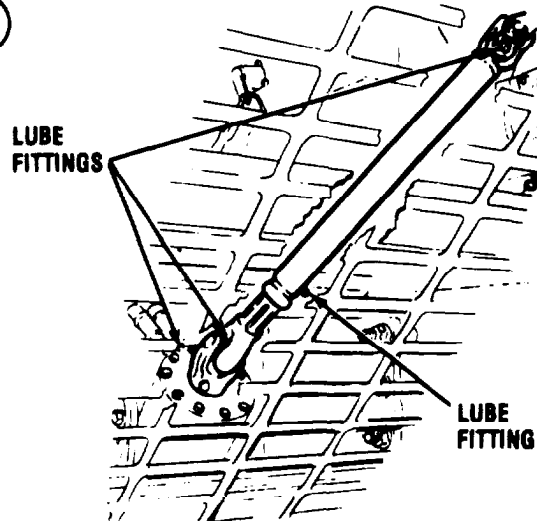

U-JOINTS AND SPLINED SHAFT

W

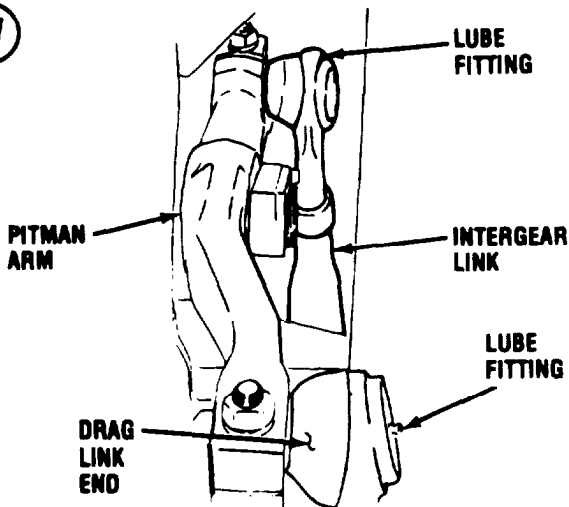

PITMAN ARM, MAIN STEERING GEAR  
(Seen from below cab)

X

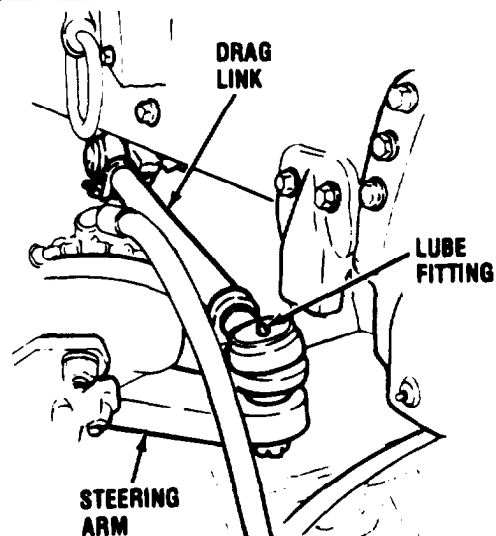

DRAG LINK AND STEERING ARM  
(No. 1 axle)

Y

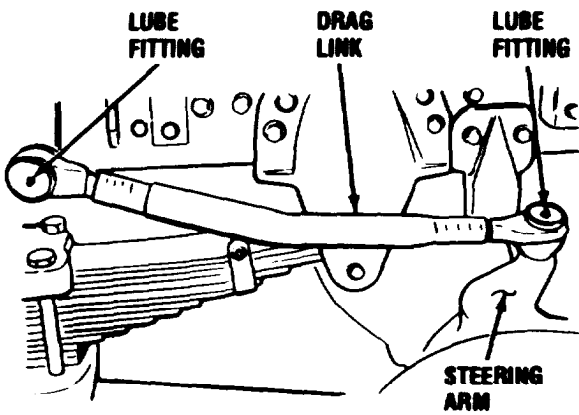

**DRAG LINK AND STEERING ARM**  
(No. 2 axle)

Z

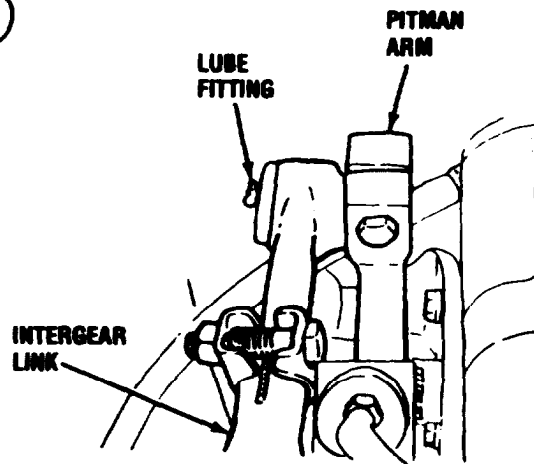

**INTERGEAR LINK AND SLAVE STEERING GEAR  
PITMAN ARM**  
(Left engine cover removed)

AA

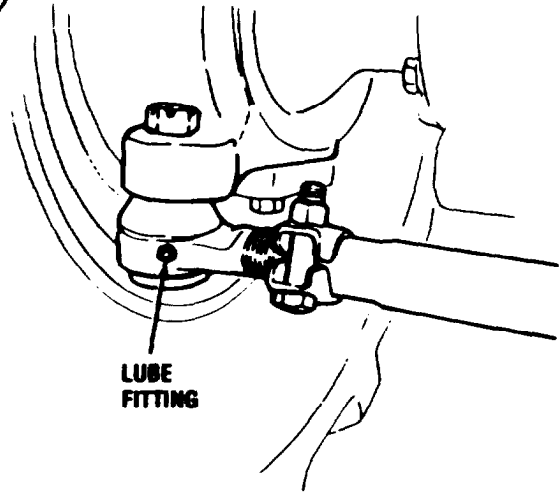

**TYPICAL TIE ROD END**

AB

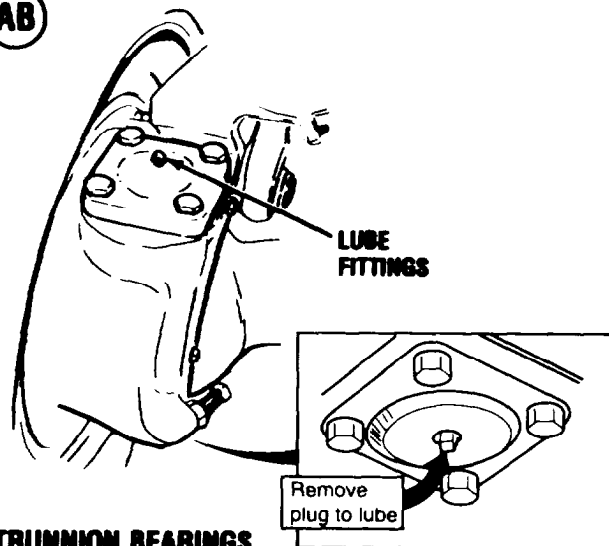

**TRUNNION BEARINGS**  
(Right Side)

AC

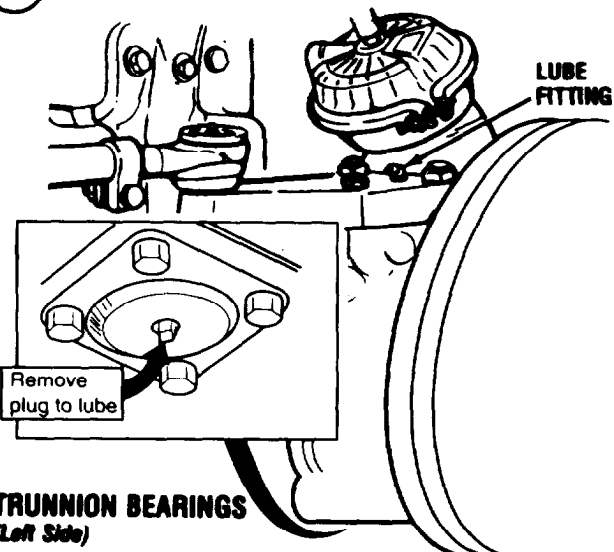

**TRUNNION BEARINGS**  
(Left Side)

AD

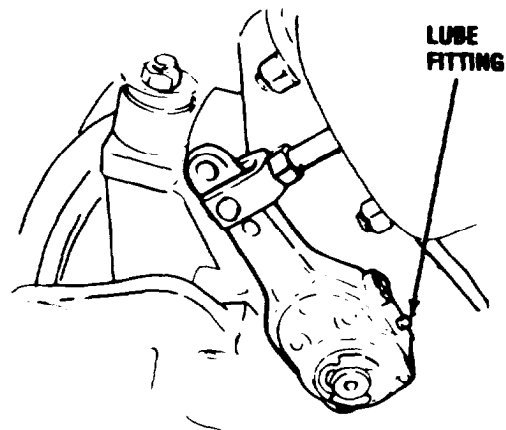

**NO. 1 AXLE SLACK ADJUSTER AND  
BRAKE CAMSHAFT**

**AE**

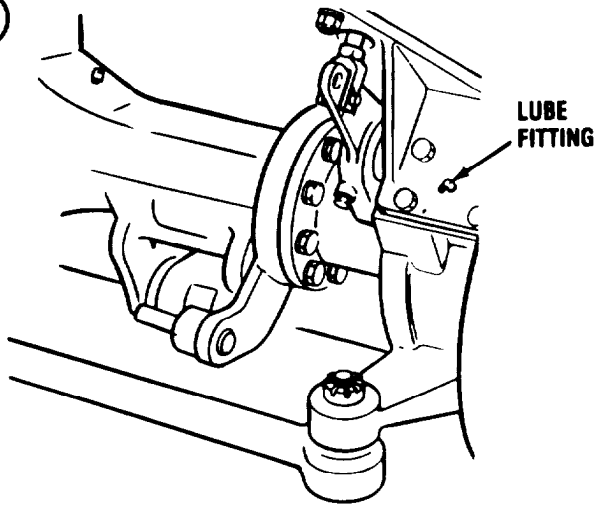

**NO. 2 AXLE SLACK ADJUSTER AND BRAKE CAMSHAFT**

**AF**

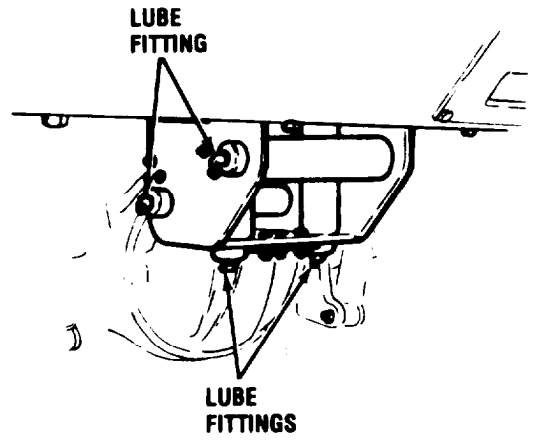

**FRONT CABLE GUIDE**

**AG**

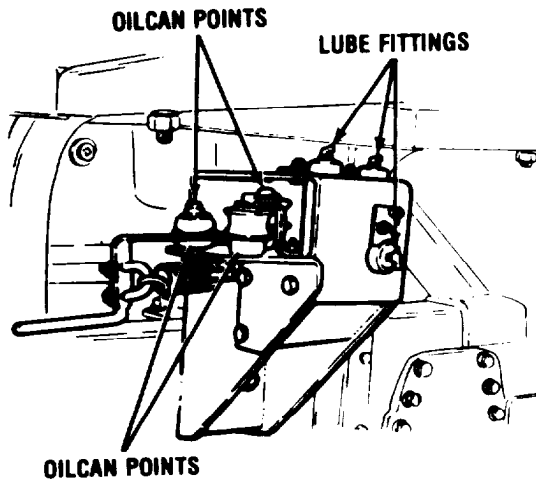

**FRONT AND REAR CABLE TENSIONERS**

**AH**

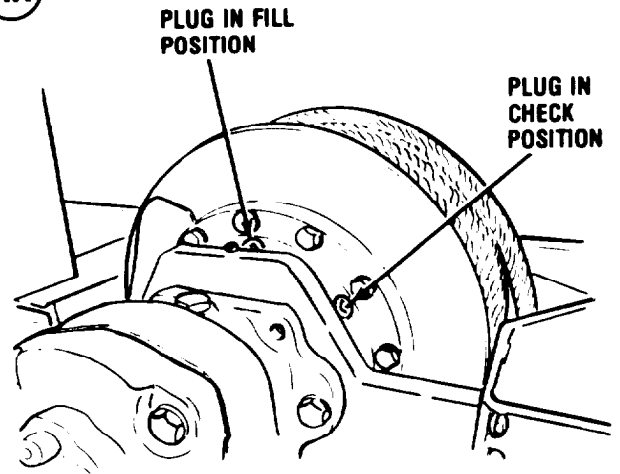

**SELF-RECOVERY WINCH CHECK AND FILL**

**AI**

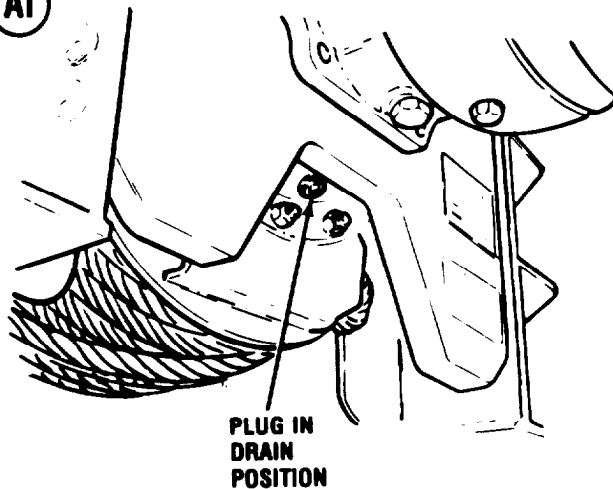

**SELF-RECOVERY WINCH DRAIN**

**AJ**

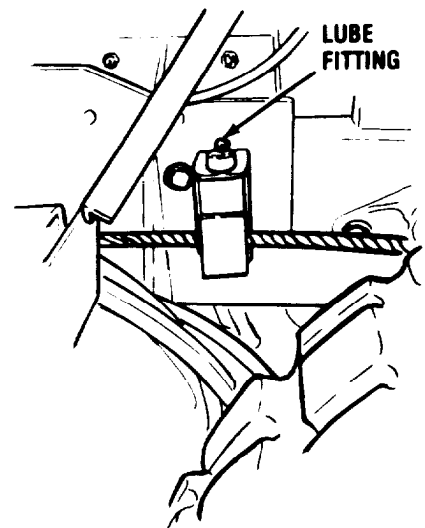

**SMALL REAR CABLE GUIDE**

**AK**

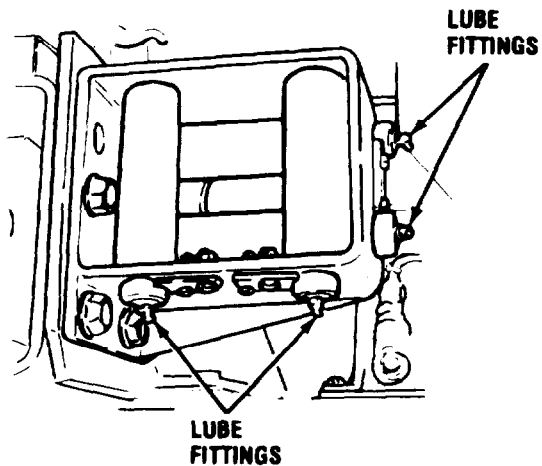

**REAR CABLE GUIDE**

**AL**

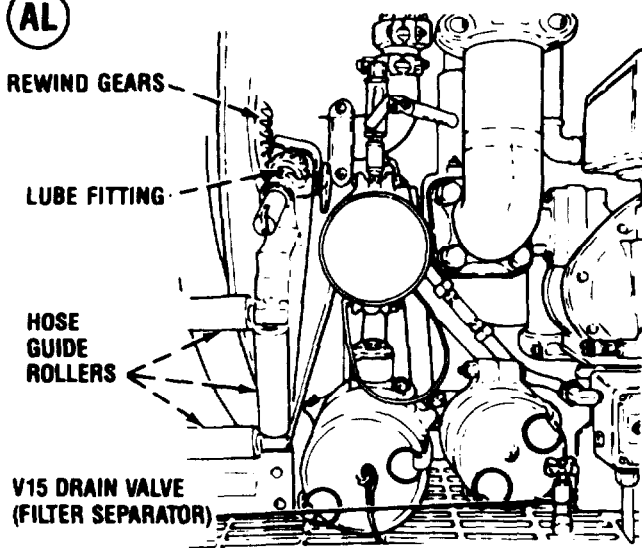

**FUEL HOSE REEL AND GUIDE ROLLERS**

**AM**

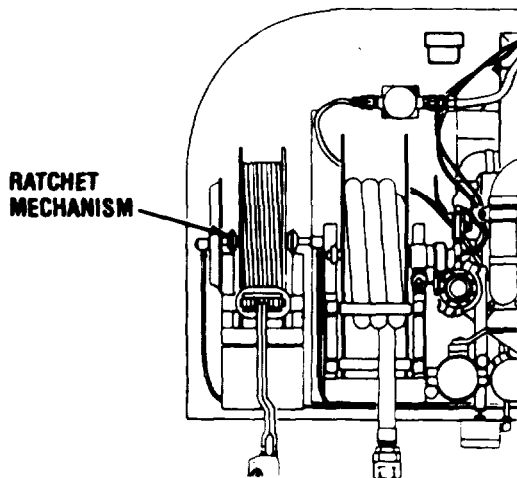

**DEADMAN CONTROL REEL OILCAN POINTS**

**AN**

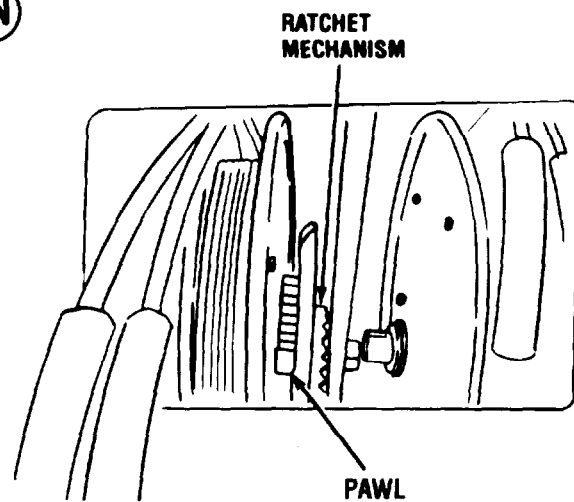

**STATIC DISCHARGE LINE REEL OILCAN POINTS**

**AO**

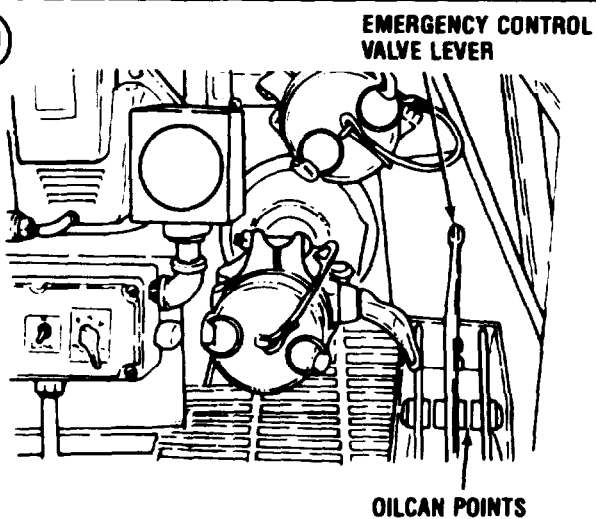

**EMERGENCY CONTROL VALVE LEVER**

**AP**

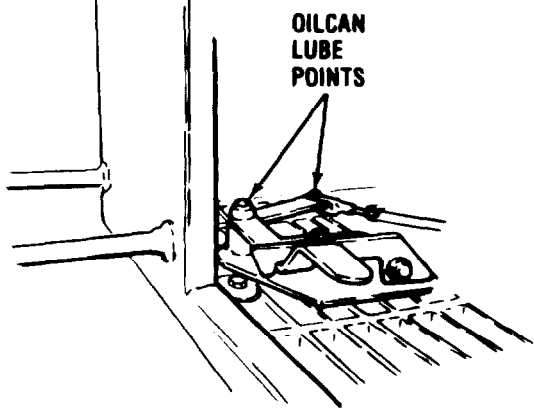

**PUMP ENGAGEMENT LEVER**

**AQ**

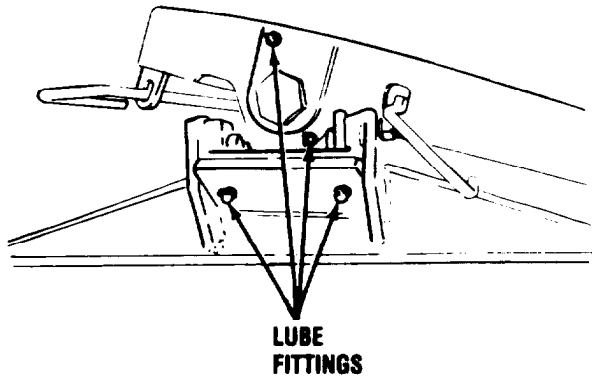

**FIFTH WHEEL  
(Left Side)**

**AR**

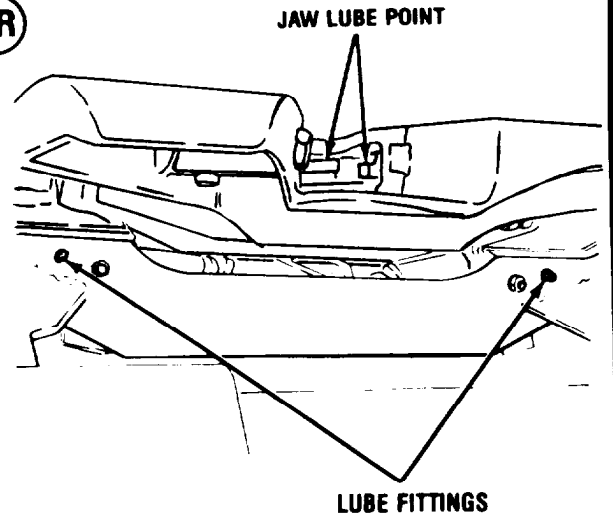

**FIFTH WHEEL  
(Rear)**

**AS**

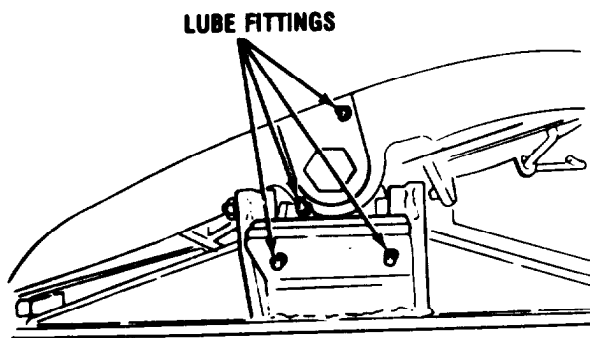

**FIFTH WHEEL  
(Right Side)**

**AT**

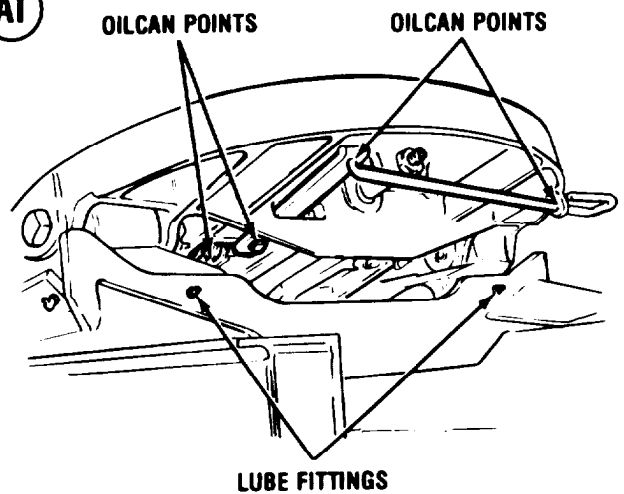

**FIFTH WHEEL  
(Front)**

**AU**

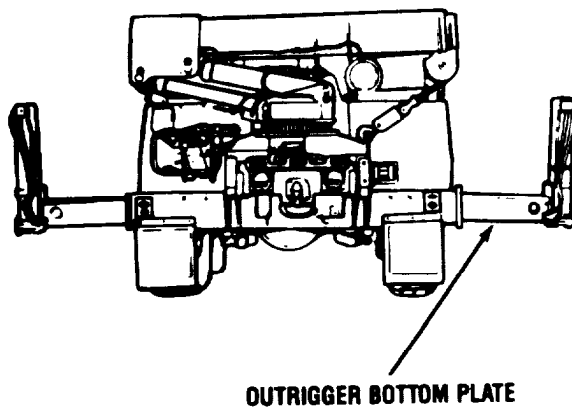

**OUTRIGGER BOTTOM PLATE**

**AV**

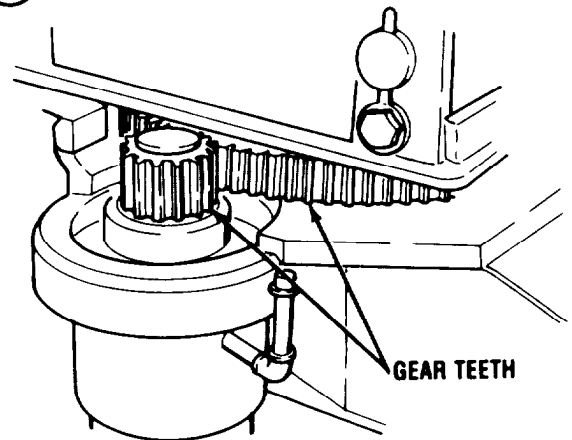

**ROTATION GEAR BEARING AND PINION TEETH**

**(AW)**

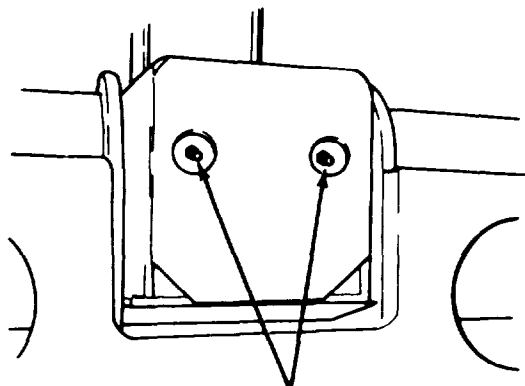

**LUBE FITTINGS**

**LOWER MAST PIVOT**

**(AX)**

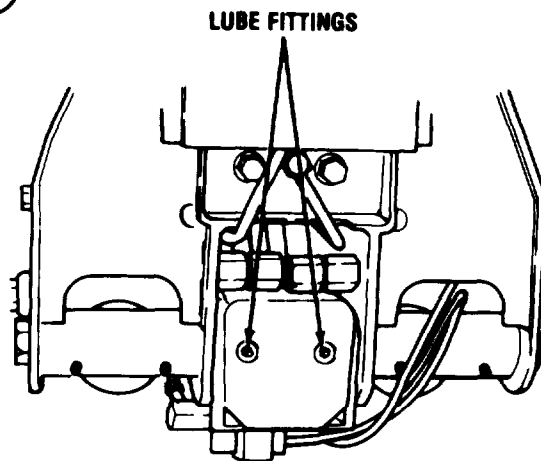

**LUBE FITTINGS**

**UPPER MAST PIVOT**

**(AY)**

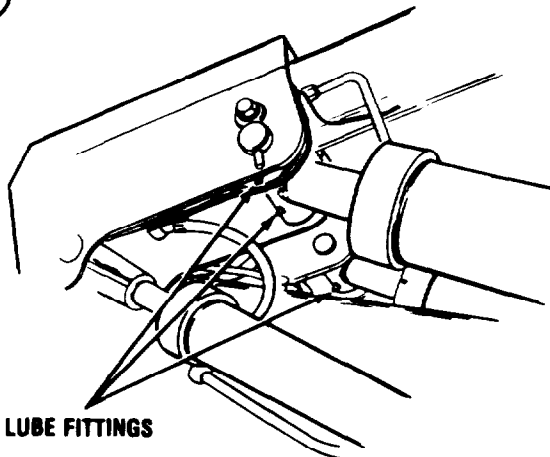

**LUBE FITTINGS**

**UPPER LIFT CYLINDER PIVOT**

**(AZ)**

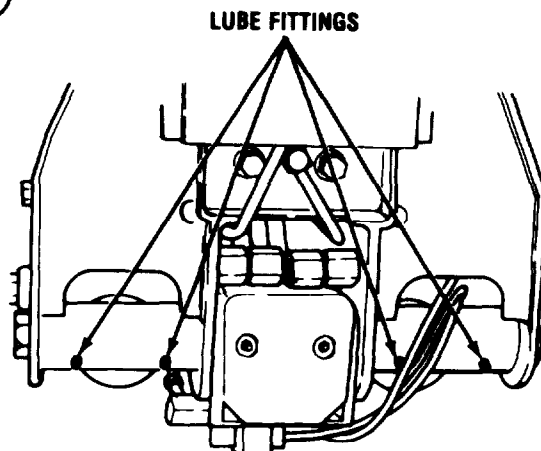

**LUBE FITTINGS**

**UPPER ERECTION CYLINDER PIVOT**

**(BA)**

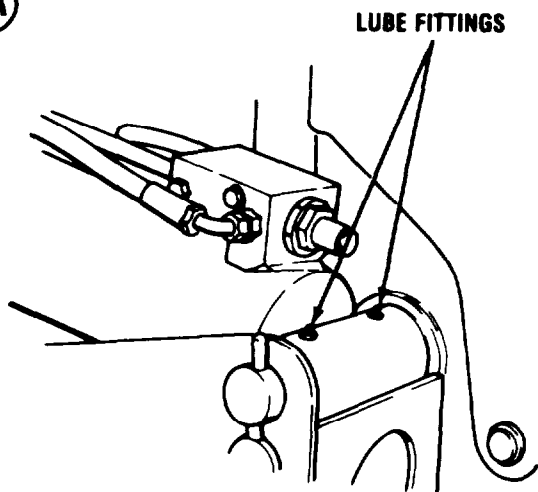

**LUBE FITTINGS**

**LOWER LIFT CYLINDER PIVOT**

**(BB)**

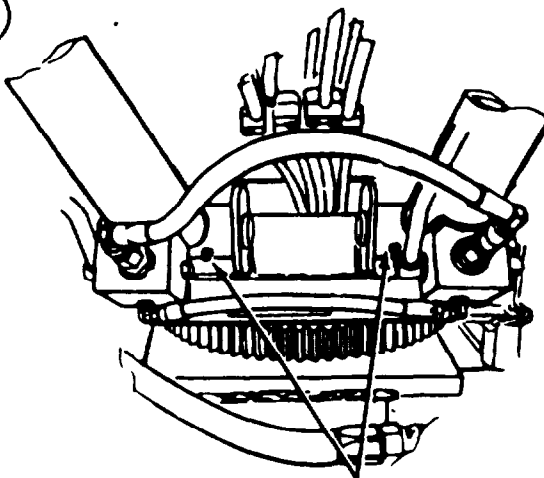

**LUBE FITTINGS**

**LOWER ERECTION CYLINDER PIVOT**



**BC**

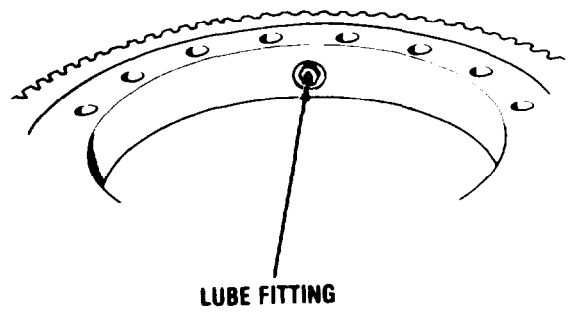

LUBE FITTING

**TURNTABLE BEARING**

**BD**

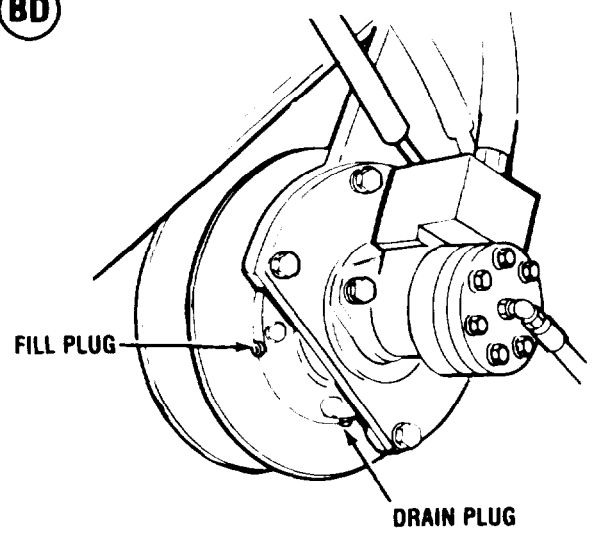

FILL PLUG

DRAIN PLUG

**CRANE HOIST DRIVE**

**BE**

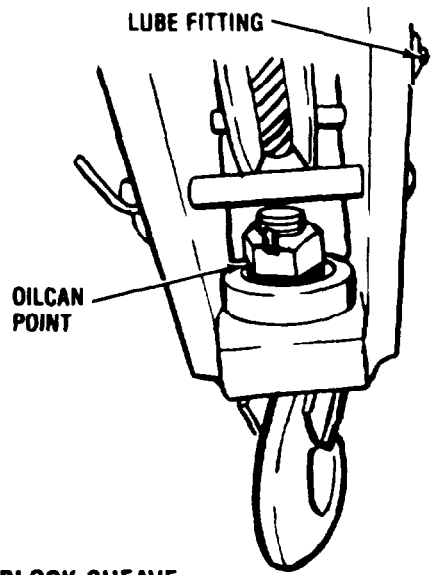

LUBE FITTING

OIL CAN POINT

**HOOK BLOCK SHEAVE**

**BF**

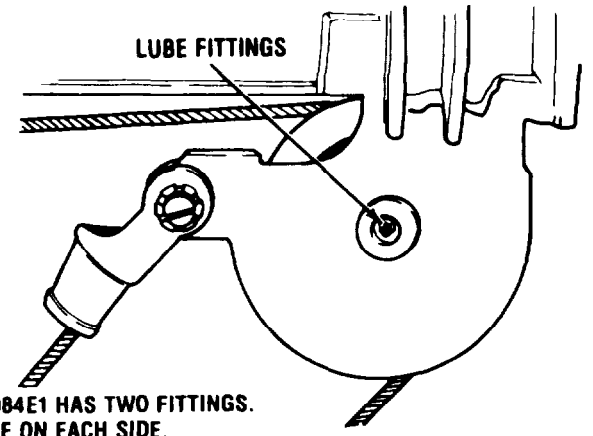

LUBE FITTINGS

M984E1 HAS TWO FITTINGS.  
ONE ON EACH SIDE.  
M977 AND M985 HAVE ONE FITTING.

**BOOM NOSE SHEAVE**

**BG**

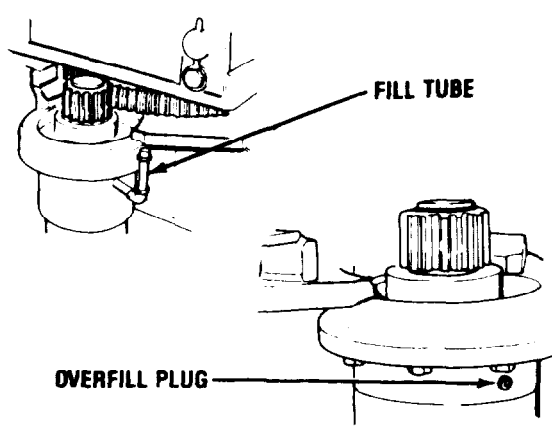

FILL TUBE

OVERFILL PLUG

**SWING DRIVE GEAR BEARING**

**BH**

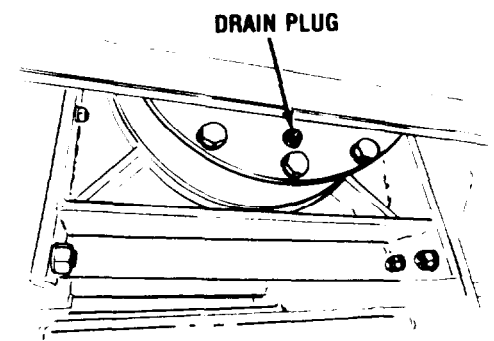

DRAIN PLUG

**DRUM GEARBOX**

**BI**

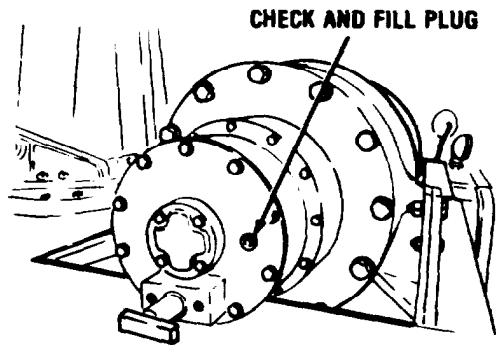

**DRUM GEARBOX**

**BJ**

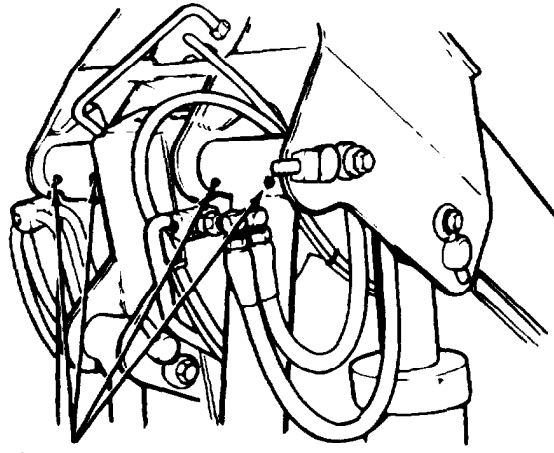

**LUBE FITTINGS**

**UPPER TENSION LINK PIVOT**

**BK**

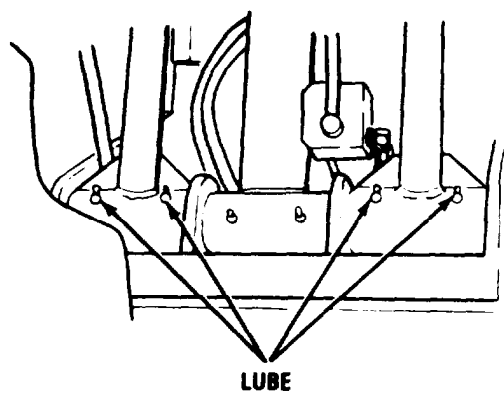

**LUBE**

**LOWER TENSION LINK PIVOT**

**BL**

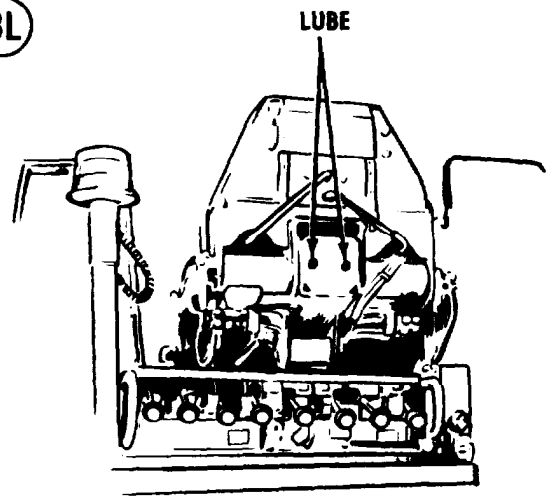

**LUBE**

**UPPER MAST PIVOT**

**BM**

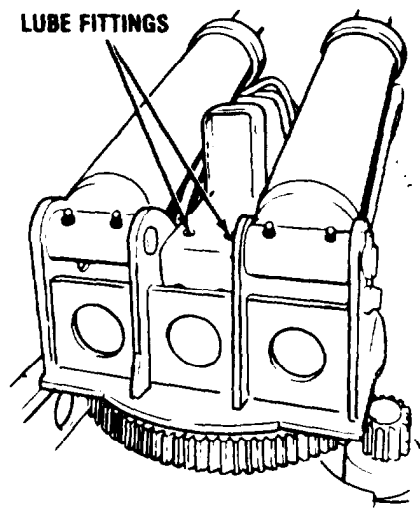

**LUBE FITTINGS**

**LOWER MAST PIVOT**

**BN**

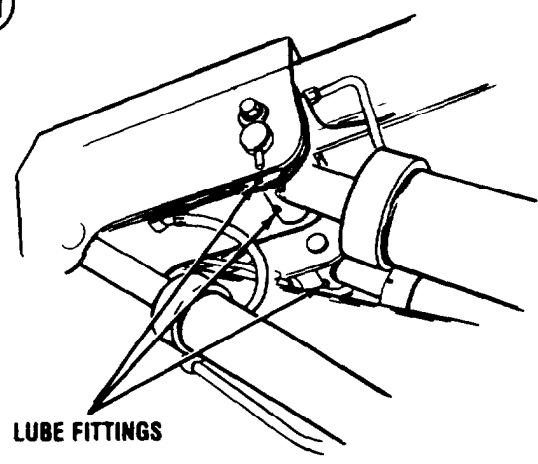

**LUBE FITTINGS**

**UPPER LIFT CYLINDER PIVOT**

**(BO)**

**LUBE FITTINGS**

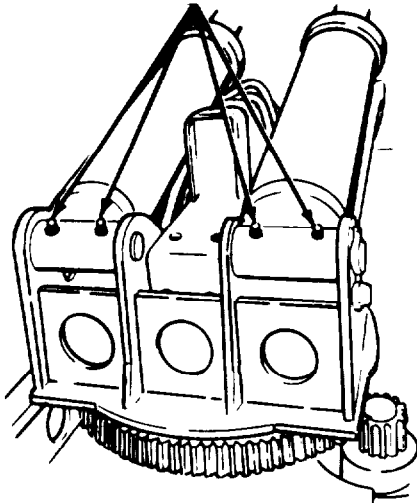

**LOWER LIFT CYLINDER PIVOT**

**(BP)**

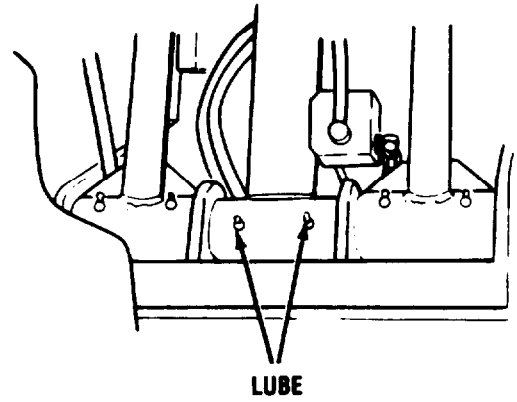

**LOWER ERECTION CYLINDER PIVOT**

**(BQ)**

**OILCAN POINT**

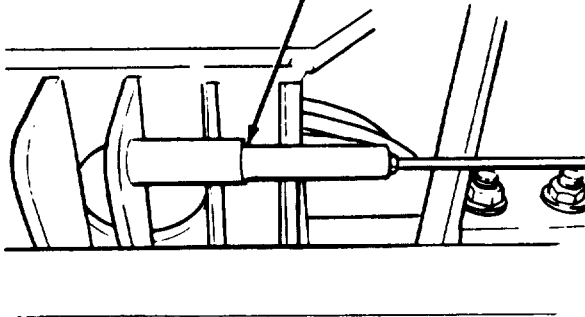

**HOOK BLOCK LOCK PIN**

**(BR)**

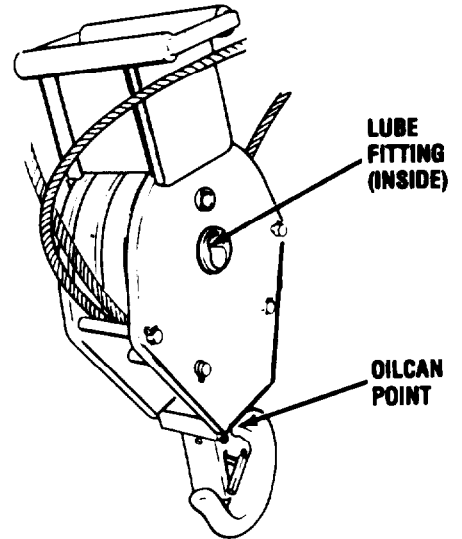

**HOOK BLOCK**

**(BS)**

**TURN TO REMOVE FILTER**

**TURN TO REMOVE PLUG**

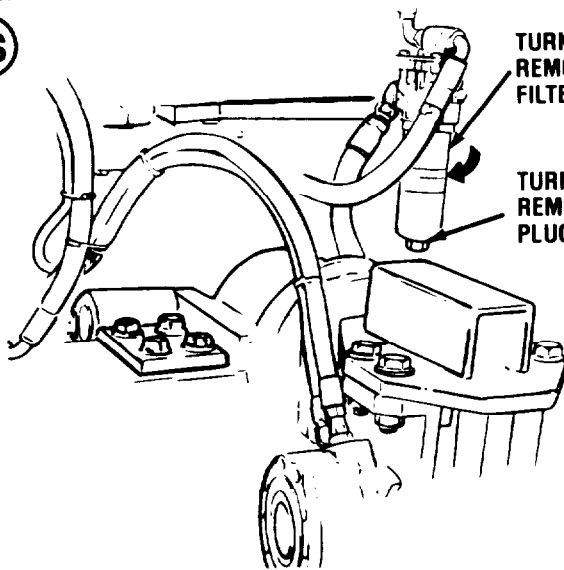

**HYDRAULIC FLUID FILTER**

**(BT)**

**OILCAN POINT**

**LUBE FITTING (BOTTOM OF ROD)**

**WISE**

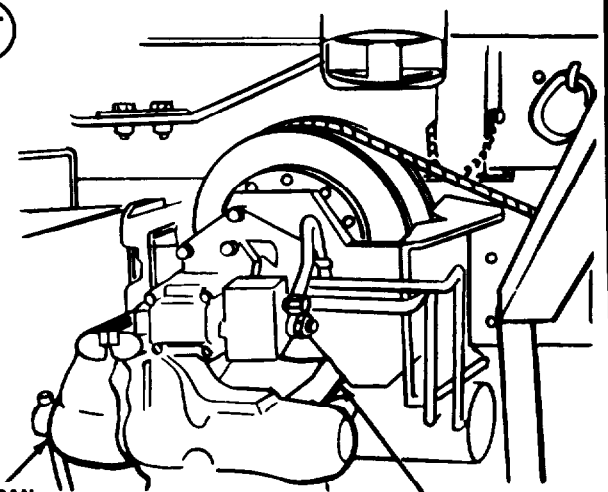

**BU**

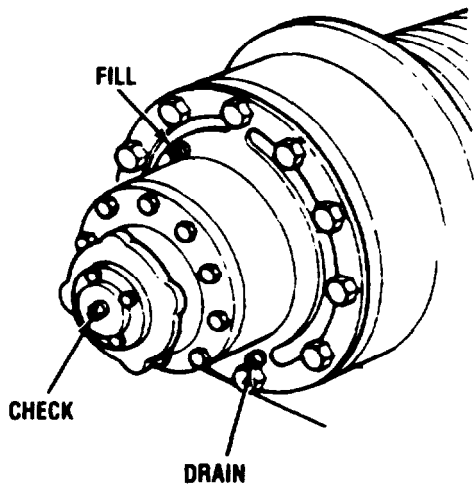

**HEAVY-DUTY WINCH**

**BV**

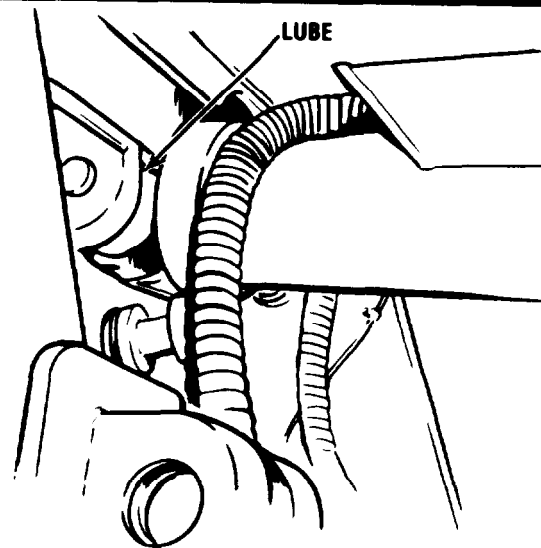

**UPPER LIFT CYLINDER PIVOT**

**BW**

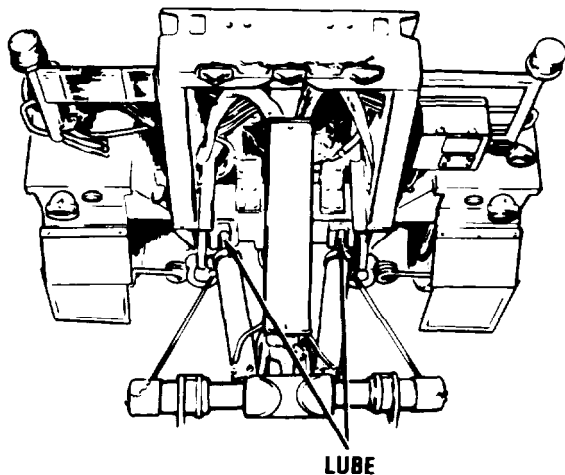

**POSITIONING CYLINDER PIVOT**

**BX**

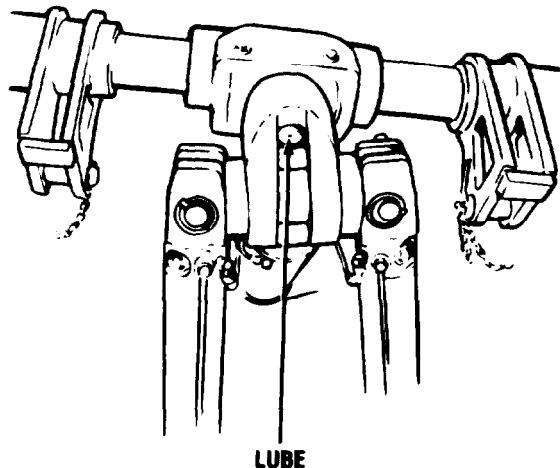

**CROSSTUBE PIVOT**

**BY**

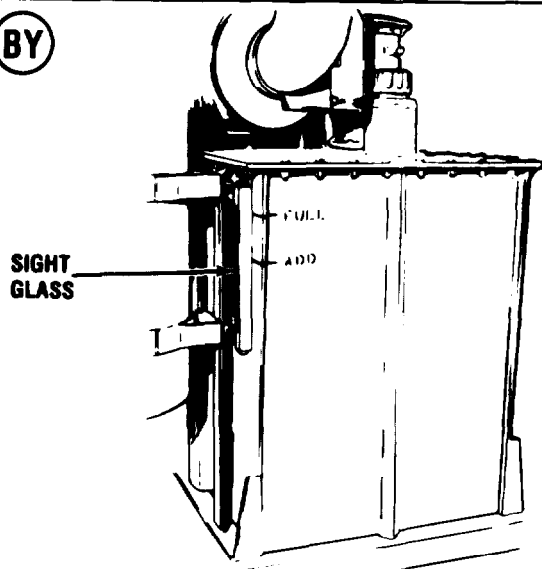

**HYDRAULIC RESERVOIR SIGHT GLASS**

**BZ**

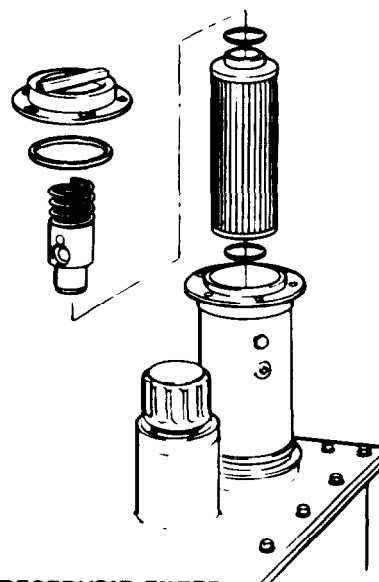

**HYDRAULIC RESERVOIR FILTER**

CA

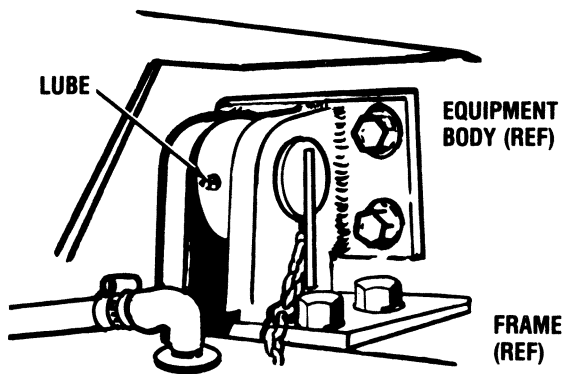

(LEFT & RIGHT SIDE SHOWN)

FRONT EQUIPMENT BODY SUPPORT

CB

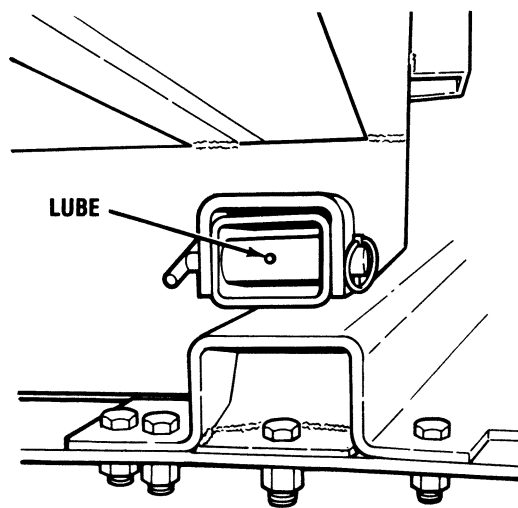

REAR EQUIPMENT BODY SUPPORTS

CC

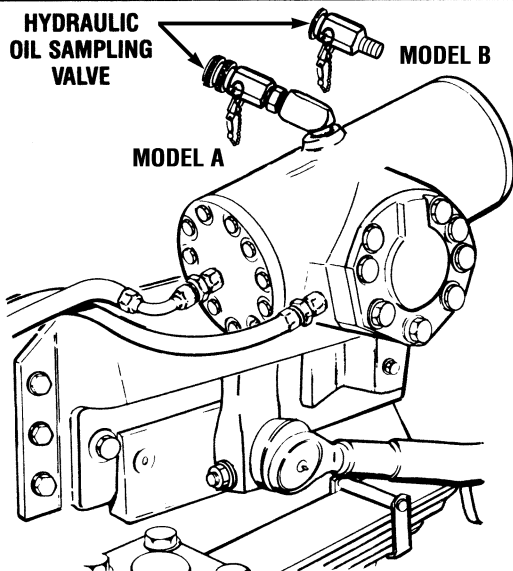

SLAVE STEERING GEAR OIL SAMPLING VALVE

CD

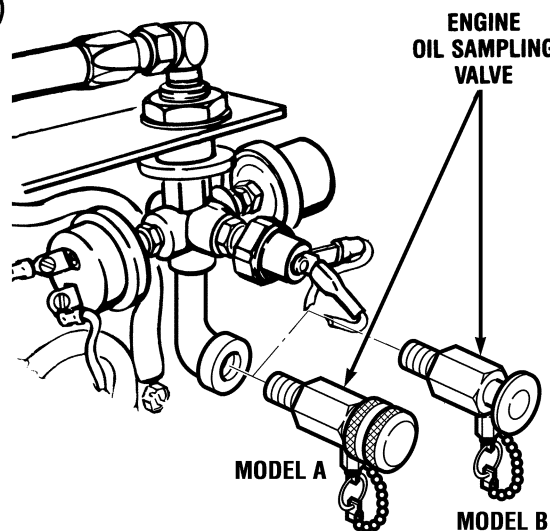

ENGINE OIL SAMPLING VALVE

CE

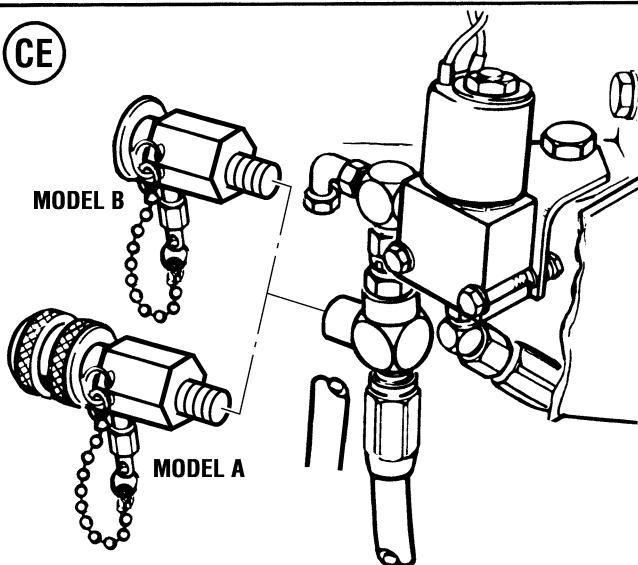

TRANSMISSION OIL SAMPLING VALVE

CF

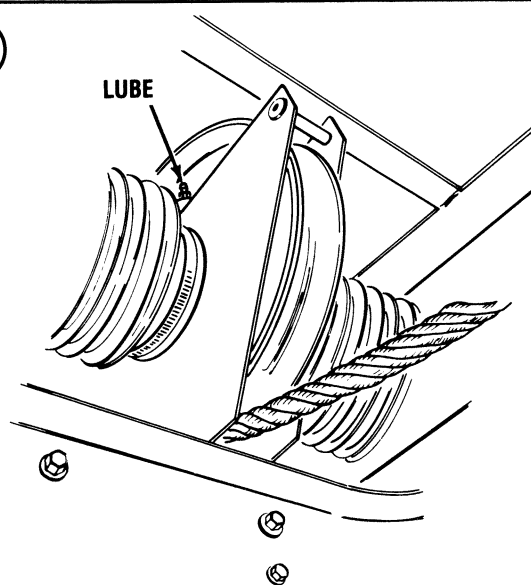

CABLE GUIDE

CG

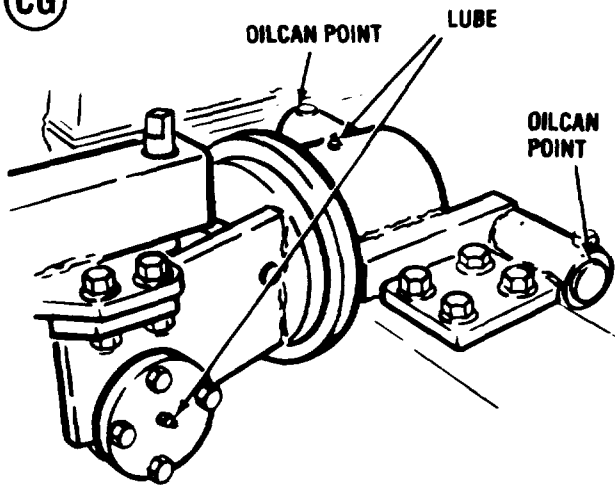

FAIRLEAD/TENSIONER

CH

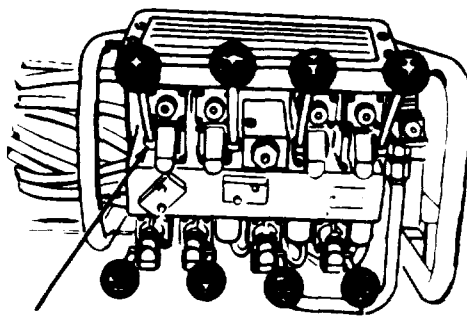

OIL CAN POINTS  
8 LOCATIONS

M977, M985 CRANE CONTROL LEVERS

CJ

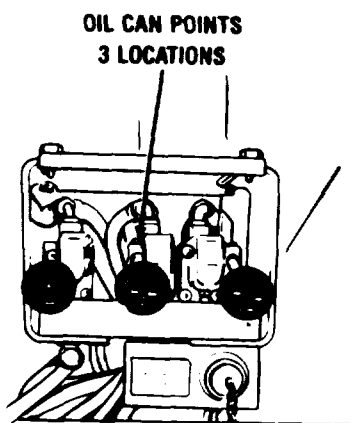

OIL CAN POINTS  
3 LOCATIONS

M984E1 CRANE CONTROL LEVERS (LEFT SIDE)

CF

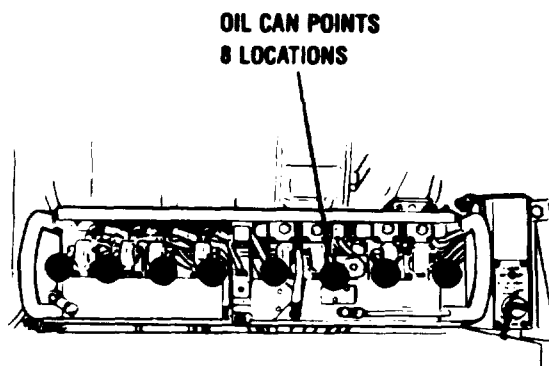

OIL CAN POINTS  
8 LOCATIONS

M984E1 CRANE CONTROL LEVERS (RIGHT SIDE)

CG

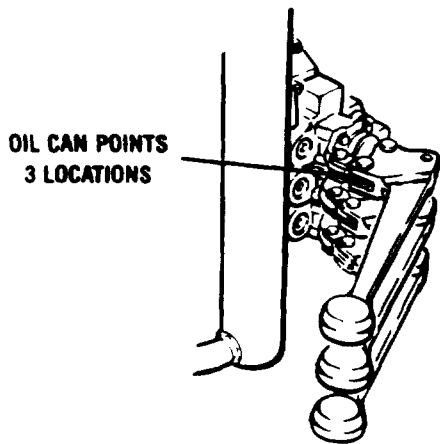

OIL CAN POINTS  
3 LOCATIONS

RETRIEVER ASSEMBLY LEVERS

CK

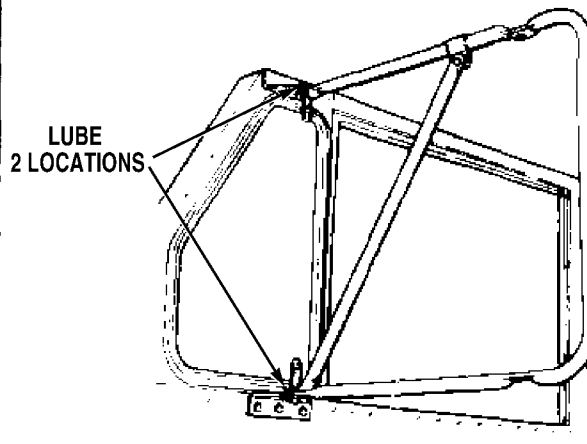

LUBE  
2 LOCATIONS

MIRROR ASSEMBLY SWIVEL JOINTS

## NOTES

### 1. COLD TEMPERATURE OPERATION.

For operating of equipment in expected continuous temperatures below 0°F (-18°C), remove lubricants prescribed in the key for temperatures above 0°F (-18°C). Relubricate with lubricants specified in the key for temperatures 0°F to 50°F (-18°C to -46°C). After changing to OEA, drain one pint of oil from oil sampling valve.

### 2. CHASSIS.

**a. *Purging of Lubricant.*** When using a grease gun, apply lubricant to the fitting until clean lubricant squeezes out of the part being lubricated.

#### **WARNING**

DO NOT START ENGINE OR MOVE VEHICLE WHEN ANYONE IS UNDER VEHICLE OR WORKING ON BRAKE LINES. SEVERE INJURY OR DEATH COULD RESULT.

**b. *Universal Joints.*** Use the proper lubricant to purge all four bearing seals of each universal joint. This flushes abrasive contaminants from each bearing and assures all four bearings are filled properly. Pop the seals, these seals are made to be popped.

If any seals fail to purge, move propeller shaft from side-to-side while applying gun pressure. This allows greater clearance on thrust end of bearing that is not purging. If seals still do not purge, rock vehicle by releasing the parking brake, start engine, put transmission in D or R, and allow vehicle to roll. This removes the windup in the drive line and allows for a greater clearance on the thrust end of the universal joint. Because of the design of the universal joint seal, there will occasionally be one or more bearing seals of a joint that may not purge. Seal tension then has to be released. The procedure for releasing seal tension is as follows.

#### **NOTE**

Universal joint may have one or two grease fittings. If there are two grease fittings, either fitting can be greased. It is not necessary to grease both fittings.

Loosen bolts holding bearing assembly that does not purge to release seal tension. It may be necessary to loosen bearing assembly approximately 1/16-inch minimum. If loosening does not result in purging, remove bearing assembly to determine cause of blockage.

#### **NOTE**

When sure of proper lubrication, run bolts down until bearing plates are flush to yoke races, then back off slightly. Retighten to torque specifications. Bend tabs against sides of bolt heads to lock bolts in place.

**c. *Drive Shaft Slip Joints.*** When lubricating spline end of propeller shafts, apply grease to spline fitting until lubricant appears at pressure relief hole. Cover hole with finger and continue adding grease until it appears at sleeve yoke seal.

**d. *Severe Operating Conditions.*** When vehicle is operating under severe conditions, lubricate propeller shafts and universal joints every 50 hours.

**e. *Front Wheel Bearings.*** See TM 9-2320-279-20 for bearing removal and installation.

**f. *Pintle Hook Plate Lubrication Fitting.*** Can be on any side.

**g. *Spring Hangers.*** If spring hanger pin does not accept grease, relieve load on spring pin by jacking vehicle up by frame rails as close to spring pin as possible. If spring pin still fails to take grease, notify Direct Support Maintenance to remove spring pin and/or bushing and replace if necessary.

### 3. ENGINE, TRANSMISSION, HYDRAULIC SYSTEM.

**a. *Cooling System Service.*** See TM 9-2320-279-10. Coolant level should be up to bottom of filler neck. Add 3% ratio by volume of corrosion inhibitor to cooling system.

**b. *Transmissions.*** Operate engine 1 minute at 1000 RPM, then idle until engine temperature reaches 60-120\_F (16-49\_C). With engine idling, check transmission dipstick. If oil level is on or below COLD RUN line, add oil. Approximately 1 Qt (0.9L) of oil is required to bring oil level from bottom of COLD RUN band to middle of COLD RUN band. See TM 9-2320-279-20.

**c. *Crankcase.*** Check oil level with vehicle parked on level ground and the engine off and cool. Do not over fill. Drain crankcase when hot.

**d. *Engine Oil Filter.*** Oil filter(s) shall be serviced/cleaned/changed, as applicable, when they are known to be contaminated, clogged or service is recommended by AOAP laboratory analysis or at prescribed hardtime intervals of 3,000 miles (4 800 kilometers) or 6 months, whichever occurs first. When oil samples are rejected and the AOAP recommends changing lubricant and filter(s), hardtime filter service clock restarts at "0". After installing new filter elements, fill crankcase; operate engine 5 minutes and check housing for leaks. Shut down engine; check crankcase oil level and bring to full mark.

**e. *Army Oil Analysis Program (AOAP).*** Refer to TB 43-0210 for sampling requirements.

## NOTES

*h.* After expiration of warranty, active Army units will send an engine oil sample to an AOAP laboratory for analysis every 100 hours of operation or 90 days, whichever occurs first. Reserve and National Guard units will send an oil sample to an AOAP laboratory for analysis every 100 hours of operation or 180 days, whichever occurs first.

*i.* Intervals for sampling as well as draining and refilling lubricants may be changed by an AOAP laboratory.

*j.* If AOAP laboratory support is not available, drain and refill crankcase oil every 3,000 mi (4 900 km) or every 6 months, whichever comes first, and drain and refill transmission oil every 6,000 mi (9 700 km) or annually, whichever comes first. Drain and refill hydraulic reservoir every 6,000 mi (9 700 km) or annually, whichever comes first.

(1) Crankcase oil will be changed only when directed by an oil analysis laboratory. When AOAP laboratory support is not available, change oil and filter element(s) at prescribed hardtime intervals, 3,000 mi (4 800 km) or 6 months, whichever occurs first.

(2) Transmission oil will be sampled every 90 days or 1,000 mi (1 600 km), whichever occurs first. Reserve and National Guard units will sample every 180 days or 1,000 mi (1 600 km), whichever occurs first. Transmission oil will be changed only when directed by an oil analysis laboratory. When AOAP laboratory support is not available, change oil each 6,000 mi (9 600 km) or 12 months, whichever occurs first.

(3) Transmission filter(s) shall be serviced/cleaned/changed, as applicable, when they are known to be contaminated, clogged or service is recommended by AOAP laboratory analysis or at prescribed hardtime intervals of 6,000 mi (9 600 km) or 12 months, whichever occurs first. When oil samples are rejected and the AOAP recommends changing lubricant and filter(s), the hardtime filter service clock restarts at "0".

(4) Hydraulic reservoir oil will be sampled every 12 months. Oil will be changed only when directed by an oil analysis laboratory. When AOAP laboratory support is not available, change oil every 6,000 mi (9 600 km) or 12 months, whichever occurs first.

(5) Hydraulic filter(s) shall be serviced/cleaned/changed, as applicable, when they are known to be contaminated, clogged or service is

recommended by AOAP laboratory analysis or at prescribed hardtime intervals of 400 hours or 6 months, whichever occurs first. For oil samples that are rejected and the AOAP recommends changing lubricant and filter(s), the hardtime filter service clock restarts at "0".

(6) The top trunnion bearing should be given 10-12 strokes with a grease gun through existing grease fitting.

(7) The plug below the trunnion bearing (Views AB and AC) should temporarily be removed and a grease fitting installed. The lower trunnion bearing should be lubed with 10-12 strokes from the grease gun. The fitting should then be removed and the plug reinstalled.

### *k. Hydraulic Oil Reservoir.*

To drain oil reservoir, remove bottom drain plug (See TM 9-2320-279-20).

**3. FIFTH WHEEL.** Clean and recoat the parts more often when the vehicle is operated in sandy or dusty conditions. Lubricate daily under severe operating conditions.

## **6 CRANES AND WINCHES.**

*a.* Lubricate outrigger bottom plate, boom wear pads, and exposed rotation gears more often when cranes are operated in sandy or dusty conditions.

*b.* Change oil in winch gearbox after the first 10 hours of *winch* operation.

*c.* To check and fill self-recovery winch, plug must be in upper position. To drain self-recovery winch, plug must be in lower position.

*d.* Heavy-duty winch is lubricated by the hydraulic oil and needs no further lubrication.

*e.* Lubricate after high-pressure wash.

*f.* Remove grease at first service interval. Lubricate with paste wax.

## **6 AXLE DIFFERENTIALS AND POWER DIVIDERS.**

*a.* Change lubricant in new or rebuilt axles within 1,000 mi (1 600 km) but no sooner than 500 mi (800 km). Following initial drain, change lubricant every 20,000 mi (32 000 km) or each 2 years of service, whichever comes first. During all lubricant changes, remove metal particles from magnetic drain and filler plugs.



## NOTES

b. During lubricant changes on the No. 2 and No. 3 axles, **clean** the lube pump filter screen. To completely drain No. 2 and No. 3 axles, remove plug at bottom of power divider in addition to drain plug in bottom of differential housing.

c. Fill No. 1 and No. 2 differential housings to a level even with bottom of CHECK and FILL plug hole.

d. When filling No. 3 and No. 4 differentials, fill to bottom of CHECK and FILL hole, then raise one end of axle 8 in. (203 mm) to allow lubricant to flow out to wheel bearing. Lower the axle and refill. Raise other end of axle the same way, then lower and refill again.

e. When refilling No. 2 and No. 3 differentials, add 1 Qt (0.94 L) of lubricant through fill hole in top of power divider.

**7. OILCAN POINTS. Every 1,000 mi (1 600 km) or monthly;** lubricate doors, side panels and engine cover hinges, locks, and latches.

Copy of this lubrication order will remain with the equipment at all times; instructions contained herein are mandatory.

**By Order of the Secretary of the Army:**

**DENNIS J. REIMER**  
*General, United States Army*  
*Chief of Staff*

Official:

  
**JOEL B. HUDSON**  
*Administrative Assistant to the*  
*Secretary of the Army*  
**05660**

DISTRIBUTION:

To be distributed in accordance with the Initial Distribution Number (IDN) 380553, requirements for LO 9-2320-279- 12.

